

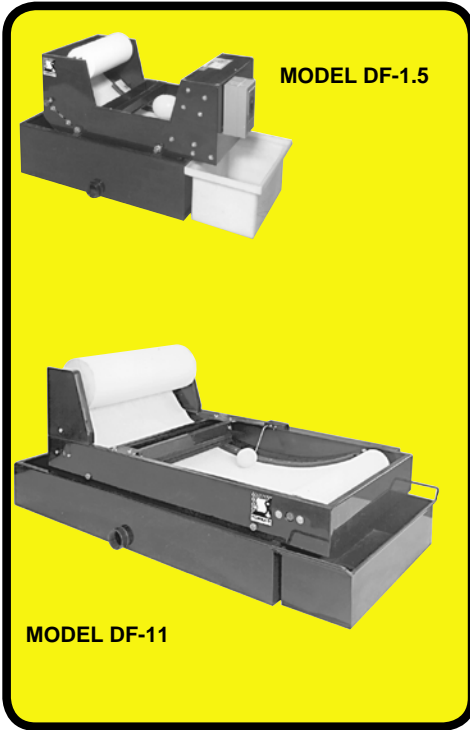

SERIES 'DF' FILTRATION SYSTEMS

343

F-701R



AUTOMATIC DISPOSABLE FABRIC FILTRATION SYSTEMS FOR:

*PHOSPHATING / PARTS WASHERS
MACHINE TOOL COOLANTS
INDUSTRIAL WASTE WATER
PROCESS OR COOLING WATER
WATER WALL SPRAY BOOTHS
TREATED PLATING WASTE*

- **Unattended operation**
Automatically indexing media allows continuous filtration, even with varying input or solids content.
- **Choice of materials**
Carbon steel, 316 stainless steel, CPVC or polypropylene
- **Sizes for any application**
From 1.5 to 113 sq. ft. of filter surface area
- **Low operating cost**

SYSTEM OPERATION

This system is totally automatic and responds to wide variations in flow rate and solids concentration. Pump the contaminated solution to the diffuser tray which distributes flow across the full width of the filter bed. Particle separation starts immediately via gravity flow through the media to the clean reservoir below the conveyor frame. Filtered solution can then gravity drain to waste or be returned to the process via a pump.

Gravity flow allows gentle accumulation and settling of solids on the filter fabric. The concave configuration of the media bed accommodates the flow rate and maximizes solids loading on the fabric. As the media gradually becomes laden with solids, the solution level will slowly rise until the float switch activates the conveyer or drive motor. Consumed fabric is advanced to the sludge box as fresh media is simultaneously indexed to the solution flow.

**TYPICAL
INSTALLATION**

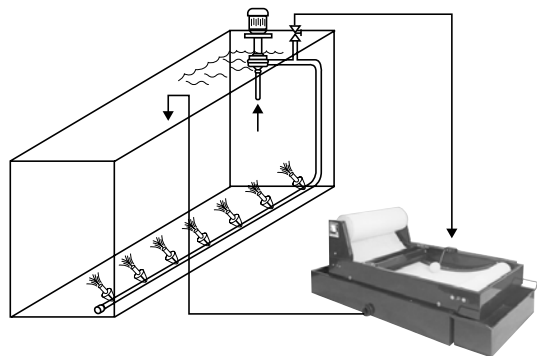



SPECIFICATIONS

SERIES S

CARBON STEEL reservoir, frame, shafts, bearings and sprockets. Models 1.5 to 11 feature a 316 stainless steel conveyor belt. Larger models have galvanized belt with optional 304 or 316 stainless steel belt. Units are coated with corrosion resistant 2-part epoxy paint.

SERIES SS

316 STAINLESS STEEL reservoir, frame, shafts, bearings, sprockets and conveyor belt. Non-wetted surfaces such as fabric bracket, motor bracket and gear reducer are carbon steel.

SERIES CPP

CPVC frame, polypropylene reservoir, conveyor belt and sprockets, Delrin® bearings, HDPE sludge box. PVC shafts on Model 1.5, 316 stainless steel shafts on Models 4 and larger.

SERIES PP

POLYPROPYLENE reservoir, frame, sprockets and conveyor belt. Delrin® bearings, PVC shaft, HDPE sludge box. Available in 1.5 size only.

All units include: float switch, sludge box (HDPE on Models 1.5 and 4), a filtrate reservoir which serves as a support for mounting the conveyor frame, drain, single phase drive motor and starter. Standard edge seals are PVC, 140°F maximum. EPDM and silicon rubber edge seals are optional. Order filter media separately.

17

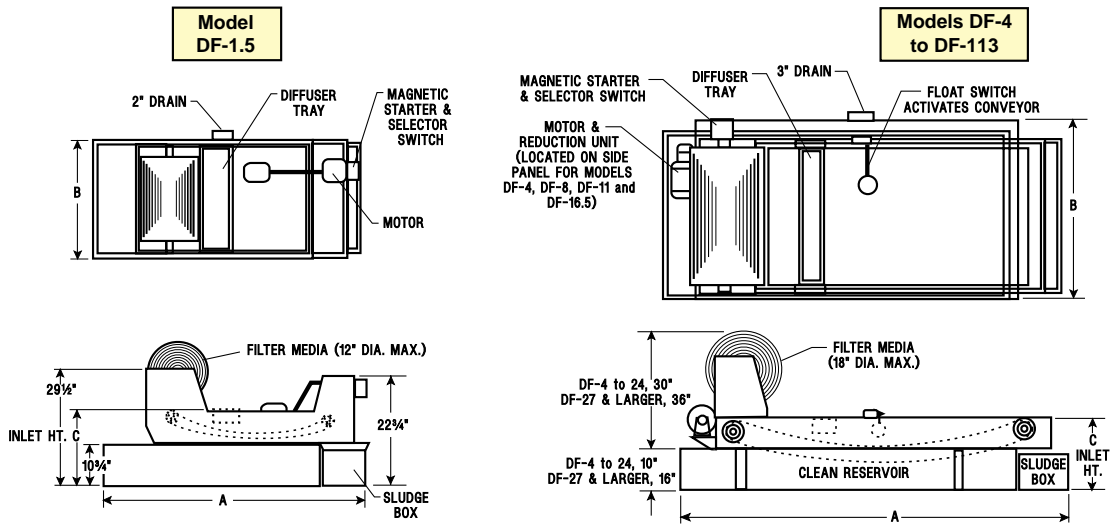

FILTER MODEL	FILTER AREA SQ. FT.	TANK CAPACITY GAL.	115V/1/60 DRIVE MOTOR HP	OVERALL DIMENSIONS (INCHES)			INLET HEIGHT (INCHES) C	MEDIA WIDTH IN.	APPROX. SHIPPING WEIGHT LBS.	FABRIC MICRON RATING				
				LENGTH A	WIDTH B	HEIGHT				GPM FLOW RATE				
										5	10	25	40	80
DF-1.5	1.5	20	1/15	55	21.5	35.5	17	13	225	2	3	4	6	9
DF-4	4	49	1/3	75	28	40	19	16.5	320	5	6	10	14	23
DF-8	8	90	1/3	71	50	40	19	33	580	10	12	20	28	45
DF-11	11	115	1/3	90	50	40	19	33	760	14	17	28	39	62
DF-15	15	130	1/3	98	44	40	18	33	940	19	23	38	53	85
DF-16.5	16.5	160	1/3	90	67	40	19	50	1025	20	25	42	58	93
DF-19	19	160	1/3	89	62	40	18	50	1025	24	29	48	67	108
DF-24	24	200	1/3	104	62	40	18	50	1420	30	36	60	84	136
DF-27	27	400	1/2	136	68	52	30	50	2400	34	41	68	95	153
DF-29	29	500	1/2	162	68	52	30	50	3110	36	44	73	102	164
DF-40	40	600	1/2	194	68	52	30	50	3750	50	60	100	140	226
DF-57	57	900	3/4	259	68	52	30	50	5250	71	80	143	200	323
DF-96	96	1370	3/4	380	68	52	30	50	7700	120	144	240	336	544
DF-113	113	1575	1	427	68	52	30	50	8655	142	160	286	400	646



TO ORDER, use Price Code Number

FILTER AREA (SQUARE FEET)	SERIES S		SERIES SS		SERIES CPP		SERIES PP	
	MODEL	PRICE CODE NO.	MODEL	PRICE CODE NO.	MODEL	PRICE CODE NO.	MODEL	PRICE CODE NO.
1.5	DFS-1.5-S	49-1414	DFS-1.5-SS	49-1413A	DFS-1.5-CPP	49-1139	DFS-1.5-PP	49-1415
4	DFS-4-S	49-1000	DFS-4-SS	49-1038A	DFS-4-CPP	49-0059	—	—
8	DFS-8-S	49-1003	DFS-8-SS	49-1040A	DFS-8-CPP	49-0060	—	—
11	DFS-11-S	49-1006	DFS-11-SS	49-1042A	DFS-11-CPP	49-0061	—	—
15	—	—	—	—	DF-15-CPP	49-0062	—	—
16.5	DFS-16.5-S	49-1007	DFS-16.5-SS	49-1043A	—	—	—	—
19	DFS-19-S	49-0015	DF-19-SS	49-0048A	DF-19-CPP	49-0064	—	—
24	DF-24-S	49-0018	DF-24-SS	49-0050A	DF-24-CPP	49-0065	—	—
27	DF-27-S	49-0021	DF-27-SS	49-0052A	DF-27-CPP	49-0066	—	—
29	DF-29-S	49-0024	DF-29-SS	49-0054A	DF-29-CPP	49-0067	—	—
40	DF-40-S	49-0027	DF-40-SS	49-0056A	DF-40-CPP	49-0068	—	—
57	DF-57-S	49-0030	DF-57-SS	49-0058A	DF-57-CPP	49-0069	—	—
96	DF-96-S	49-0074	—	—	—	—	—	—
113	DF-113-S	49-0075	—	—	—	—	—	—

ORDER DISPOSA-FABRIC MEDIA SEPARATELY, use Price Code No.

RAYON / POLYESTER BLEND	MODEL NO. *	MICRON	-13" WIDTH*				-16 1/2" WIDTH* (LOTS OF 2 ONLY)			-33" WIDTH			-50" WIDTH*		
			YARDS PER ROLL	PRICE CODE NO.	WEIGHT (LBS)	YARDS PER ROLL	PRICE CODE NO.	WEIGHT (LBS)	YARDS PER ROLL	PRICE CODE NO.	WEIGHT (LBS)	YARDS PER ROLL	PRICE CODE NO.	WEIGHT (LBS)	
															COARSE
COARSE	SF-W125	125	100	49-0257 1B	2	500	49-0090 1B	11.5	500	49-0091 1B	23	500	49-0092-1B	35	
	SF-W105	105	100	49-0258 1B	2	500	49-0093 1B	11.5	500	49-0094 1B	23	500	49-0095-1B	35	
	SF-W090	90	100	49-0259 1B	2	500	49-0165 1B	12.0	500	49-0166 1B	23	500	49-0167-1B	35	
	SF-W080	80	100	49-0260 B	2	500	49-0099 B	9.0	500	49-0100 B	18	500	49-0101 B	27	
	SF-W055	55	100	49-0262 B	2	500	49-0105 B	10.5	500	49-0106 B	21	500	49-0107 B	32	
MEDIUM	SF-W040	40	100	49-0263 B	2	500	49-0108 B	12.0	500	49-0109 B	24	500	49-0110 B	36	
	SF-W025	25	100	49-0264 B	2	500	49-0111 B	14.5	500	49-0112 B	29	500	49-0113 B	44	
	SF-W020	20	100	49-0265 B	2	500	49-0070 B	18.0	500	49-0071 B	36	500	49-0072 B	55	
FINE	SF-W010	10	50	49-0266 B	2	200	49-0114 B	14.0	200	49-0115 B	28	200	49-0116 B	43	
	SF-W005	5	50	49-0267 B	2	200	49-0117 B	17.5	200	49-0118 B	35	200	49-0119 B	53	
	SF-W001	1	50	49-0268 B	2	200	49-0120 B	27.5	200	49-0121 B	55	200	49-0122 B	84	
POLYPRO	SF-P080	80	100	49-0260 BPP	2	500	49-0099 BPP	9.0	500	49-0100 BPP	18	500	49-0101 BPP	27	
	SF-P055	55	100	49-0262 BPP	2	500	49-0105 BPP	10.5	500	49-0106 BPP	21	500	49-0107 BPP	32	
	SF-P040	40	100	49-0263 BPP	2	500	49-0108 BPP	12.0	500	49-0109 BPP	24	500	49-0110 BPP	36	
	SF-P025	25	100	49-0264 BPP	2	500	49-0111 BPP	14.5	500	49-0112 BPP	29	500	49-0113 BPP	44	
	SF-P020	20	100	49-0265 BPP	2	500	49-0070 BPP	18.0	500	49-0071 BPP	36	500	49-0072 BPP	55	

* Add width to Model No. - Example: SF-W125-13" See Flow Rate Chart and Micron Selection Guide

OPTIONAL EQUIPMENT

DESCRIPTION	PRICE CODE NO.
FLOAT ACTIVATED LEVEL CONTROL SWITCH FOR RESERVOIR PUMP NEMA 4. For single phase motors to 1 1/2 HP @ 115V or 2 HP @ 230VAC. Used as a pilot device on three phase magnetic motor starters. Complete with float ball and mounted in reservoir tank for pump-down operation. Separate motor starter is required for 3-phase motor (see below).	49-0162
RESERVOIR PUMP INSTALLATION AND WIRING	49-0173
MOTOR STARTER FOR RESERVOIR PUMP 3 phase with transformer and 24VAC control circuit 1 phase with transformer and 24VAC control circuit	O-MS3P-S O-MS1P-S
EDGE SEALS Models 1.5 - 8 Models 11 - 16.5	EPDM 200°F max. 49-0500 A 49-0651 A SILICON RUBBER 300°F max. 49-0500 B 49-0651 B
CONVEYOR BELTS For Series DF-19S through DF-113S (Standard belts are galvanized steel.) 304 stainless steel 316 stainless steel	ADD TO MODEL -304 -316 ADD TO PRICE CODE NO. B C

See page 4 for reservoir pumps.





RESERVOIR PUMPS (not installed)

FLOW		HORSEPOWER		CAST IRON		POLYPROPYLENE		CPVC	
GPM @ TDH (ft.)		CI	PP & CPVC	MODEL	PRICE CODE NO.	MODEL	PRICE CODE NO.	MODEL	PRICE CODE NO.
5	11	1/15	1/5	SCI 1.5	49-0149	E 3/4PP	45-0030A	E3/4C	45-0027 1A
15	11	1/4	—	SCI 4	49-0150	—	—	—	—
24	20	1/2	1/3	SCI 8	49-0151	EOPP1	39-1121 A	EOC1	39-1221 A
40	24	3/4	3/4	SCI 15	49-0153	EOPP3	39-1123 C	EOC3	39-1223 C
75	20	2	2	SCI 24	49-0156	EOPP4	39-2124 J	EOC4	39-2224 J
115	35	2	2	SCI 29	49-0158 A	EHP2	45-0623	EHC2	45-0123
145	25	3	5	SCI 40	49-0159	EHP5	45-0645	EHC5	45-0145
200	35	5	7 - 1/2	SCI 57	49-0160 A	—	—	EHM2	45-1211

NOTE: 1/15 HP to 3/4 HP motors are 1 phase, 1 HP and up are 3 phase. 3 phase motors require a separate motor starter.

FLOW RATE

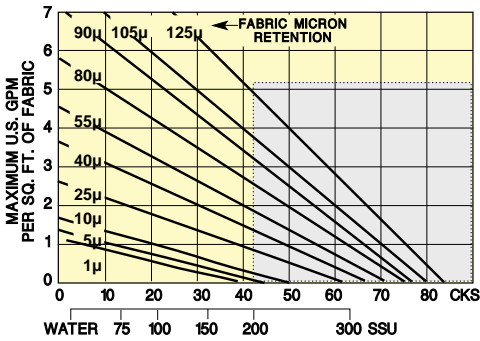

FABRIC SELECTION

APPLICATION	MICRON SELECTION GUIDE									
	125	105	90	80	55	40	25	10	5	1
Paint spray booth - water Zinc & iron phosphating	•	•	•	•	•	•	•			
Caustic washing solutions Waste treat - metal hydroxide	•	•	•	•	•	•	•	•	•	•
Grinding - steel Grinding - cast iron	•	•	•	•	•	•	•	•	•	
Grinding - aluminum Grinding - carbide			•	•	•	•	•	•	•	
Belt grinding - steel Belt grinding - zinc	•	•	•	•	•	•	•			
Grinding - hard plastics Grinding - soft plastics		•	•	•	•	•	•			
Grinding - steel roll Grinding - brass		•	•	•	•	•	•	•		
Grinding - bronze Grinding - aluminum		•	•	•	•	•	•	•		
Lapping (Oil 30 - 100) Honing (Oil 20 - 100)					•	•	•	•	•	•
Quenching Grinding - aluminum		•	•	•	•	•	•	•	•	
Belt grinding - steel Belt polishing - zinc copper	•	•	•	•	•	•	•	•		
Belt grinding - steel Thread grinding - steel	•	•	•							
Flute - tap die grinding Crush & form grinding	•	•	•							
Machine tool turning/milling			•	•	•	•	•			

SIZING INSTRUCTIONS:

- Select the desired micron retention fabric from the chart above.
- Using the Flow Rate chart on the preceding page, determine the flow per square foot for the selected viscosity and fabric.
- Divide the total flow (GPM) you desire by the number obtained in step 2. The resultant is the size, in square feet of filter area your Automatic Fabric Filter should have.

Registered Trademark: Derlin - DuPont





ROLL-A-FILTER[®]

F-703D

USING DISPOSABLE FABRIC MEDIA



Typical applications include:

- STRAINING - Paints & varnishes
- FILTERING - Chemicals, cutting and grinding fluids, oil
- PILOT TESTING - Waste treatment, phosphating

- Steel construction coated with chemically resistant, oven cured two-part epoxy paint.
- Heavy duty perforated steel filter media support basket with handles
- Rugged steel support frame and sloped bottom basin
- Safe tear bar / cutting guide
- Models RAF-2S & -3S conveniently fit standard 55 gallon drums

Simply place the ROLL-A-FILTER on top of an open drum or recirculating tank and pour or route the liquid to be filtered into the filter tray. When the filter fabric accumulates enough solids, as indicated by the liquid pool, pull it forward, tear/cut it off and discard. The handles on the filter media support basket provide an easy and clean method of lifting and discarding the sludge laden media.

All units are made of heavy gauge steel, and are designed with integral clean catch basin with center discharge hole. Units conveniently install over sumps to eliminate frequent cleanout.

TO ORDER

MODEL NUMBER	NOMINAL DIMENSIONS	MEDIA WIDTH	FILTERING AREA	SHIPPING WEIGHT	PRICE CODE NO.
	L x W x H				
	Inches	Inches	Sq. Ft.	Lbs.	
RAF-2S	28 x 19 x 5	18	2-1/3	19	79-0278
RAF-3S	28 x 25 x 5	24	3-1/4	34	79-0279
RAF-4S	47 x 25 x 5	24	6	46	79-0280
RAF-5S	47 x 37 x 5	36	9	61	79-0281
RAF-6S	59 x 37 x 5	36	12	74	79-0282

For further purification or recycling efforts, coalescing filters to separate liquids (i.e. oil/water) are available. Consult Application Engineering Department.

Note: Flow capacities vary greatly depending on liquid and volume of solids.

DISPOSABLE FABRIC MEDIA (Order separately)

	PART NUMBER	APPROXIMATE MICRON RATING	APPLICATION	FEET PER ROLL	PRICE CODE NUMBER		
					18"	24"	36"
POLY-ESTER	W105	105	Straining paint / Coarse filtration	150	49-0175-1	49-0176-1	49-0177-1
	W090	90	Fine straining / Paint filtration / Light oil	150	49-0178-1	49-0179-1	49-0180-1
RAYON	W080	80	Coarse filtration	150	49-0181	49-0182	49-0183
	W055	55	Coarse filtration	150	49-0184	49-0185	49-0186
	W040	40	Medium filtration	150	49-0187	49-0188	49-0189
	W025	25	Fine filtration	150	49-0190	49-0191	49-0192
	W010	10	Very fine filtration	75	49-0193	49-0194	49-0195
	W005	5	Ultra fine filtration	75	49-0240	49-0241	49-0242
NYLON	W001	1	Ultra fine filtration	75	49-0243	49-0244	49-0245
	N080	80	High temperature operation (to 400°F)	150	—	49-0196	—
	N040	40	Chemical applications (Fabrics have chemical resistance of nylon 6.6)	150	—	49-0197	—
	N010	5 - 10		75	—	49-0198	—

Minimum order - 2 rolls



SERIES 'CB' CARTRIDGE / BAG FILTRATION SYSTEM



Shown with cover open

For recirculating filtration on a reservoir

- COMPLETELY PRE-ENGINEERED AND ASSEMBLED
- QUICK CHANGE REUSABLE FILTER MEDIA MEANS FAST PAYBACK
- PERMITS WATER REUSE
- PREVENTS NOZZLE PLUGGING
- PROVIDES BETTER CLEANING
- PREVENTS POLLUTION
- NO BACKWASH REQUIRED
- AVAILABLE WITH AUTOMATIC ON / OFF PUMP CONTROL

The Cartridge / Bag system is a 2-stage liquid-solid separation system designed to provide high solids loading capabilities for applications requiring recirculating filtration of a process reservoir. Typical applications include the removal of particles from glass and plastic in bottle washing operations and the removal of board fiber, wheel grit, copper and other metals from water used in PC board deburring and scrubbing equipment.

The first stage employs a primary filter tank containing 8 gravity flow filter bags to collect bulk particles separated from rinse water. This stage provides 17.6 ft.² of filter surface area and is capable of filtering particles from 100 micron to 5 micron, depending upon the mi-

cron rating of the filter bags selected. The filter bags are attached to a manifold with cam-lock quick-disconnect couplings for minimal down-time when servicing. The manifold includes an overflow vent which prevents back-up of system flow.

A circulating pump can be manually activated, or automatically activated with an optional level control, to transfer the filtered water from the primary filter tank to the second stage. This stage consists of a final trap filter chamber which uses a 2 micron pleated paper filter cartridge with 32 sq. ft. of surface area to polish the water so that clear water can be recycled to the process or discharged to a drain.

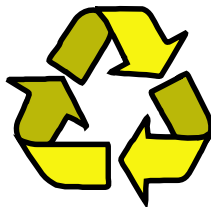

FEATURES:

- Flow control valve
- High solids loading
- Vinyl coated steel base

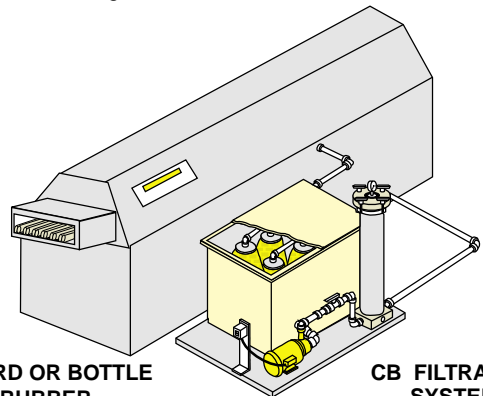

PC BOARD OR BOTTLE SCRUBBER

CB FILTRATION SYSTEM

17



SPECIFICATIONS

Entire system constructed of corrosion resistant materials for long service life.

PRIMARY FILTER TANK

Eight 5, 10, 25, 50 or 100 micron polypropylene filter bags (order separately) with quick-disconnect couplings provide 17.6 sq. ft. (1.6 sq. m) total area primary filtration by gravity flow to a 36" x 24" x 32" (914 x 610 x 813 mm) deep polyethylene reservoir. Reservoir provided with cover.

AVAILABLE WITH:

PVDF CENTRIFUGAL PUMP

Provides 30 U. S. GPM at 18 PSI @ 60 Hz (95 LPM at 1.2 bar @ 50 Hz) with Viton® mechanical seal and "O"-ring. Flow control valve on 1" PVC pipe between pump and final filter.

or

NORYL® SELF-PRIMING CENTRIFUGAL PUMP

Provides 30 U. S. GPM at 21 PSI @ 60 Hz (95 LPM at 1.4 bar @ 50 Hz) with Viton® mechanical seal and "O"-ring. Flow control valve on 1" PVC pipe between pump and final filter.

FINAL TRAP FILTER CHAMBER

Constructed of PVC with quick opening swing bolts and tee handles. Supplied with pressure gauge. Includes one 4" x 36" pleated paper filter cartridge of 2 micron, 32 sq. ft. (3.0 sq. m.) expanded filter area.

VINYL COATED STEEL BASE

Approximate shipping weight - 200 lbs. (91 kg.)

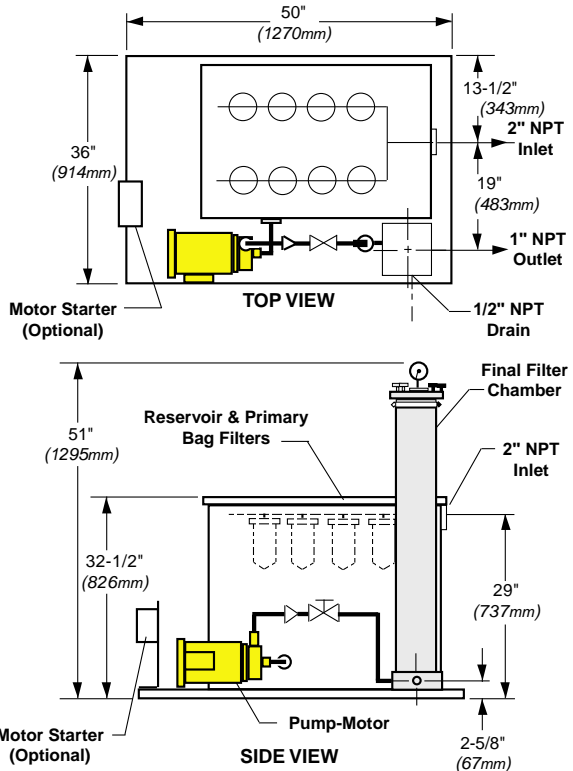

TO ORDER, use Price Code Number

MODEL with PVDF end suction 'K' pump	MOTOR	PRICE CODE NO.
	TEFC, 1.5 HP 3450 RPM @ 60 Hz 2850 RPM @ 50 Hz	
CBF 65x58 1½x1½K3V(M2)-C1.5	115-230V/1/60 230V/460V/3/60	2750
CBF 65x58 1½x1½K3V(M2)-D1.5	380V/3/50	2751

MODEL with NORYL self-priming 'G' pump	MOTOR	PRICE CODE NO.
	TEFC, 1.0 HP 3450 RPM @ 60 Hz 2850 RPM @ 50 Hz	
CBF 65x58 GNOKCVN-C1.0	115-230V/1/60 230V/460V/3/60	2733
CBF 65x58 GNOKCVN-D1.0	380V/3/50	2734

OPTIONAL

DESCRIPTION	PRICE CODE NO.
LEVEL CONTROL (motor starter required) Automatic on / off pump control	O-1490
MOTOR STARTER Watertight push button, 115-230V/1/50-60 230-460V/3/50-60	O-MS1P O-MS3P
Note: Add -S to motor starter PCN when ordering motor starter for use with O-1490 level control, i.e., O-MS3P-S	
FILTER MEDIA (Bags ordered separately, 1 cartridge included in original equipment.) Bags - Polypropylene, size 7" x 16" (8 req'd) 5 micron 10 micron 25 micron 50 micron 100 micron	88-0848A 88-0848B 88-0848C 88-0848D 88-0848E
Replacement pleated cartridge 2 micron (1 required)	PL436-2-4





RECESSED PLATE FILTER PRESS

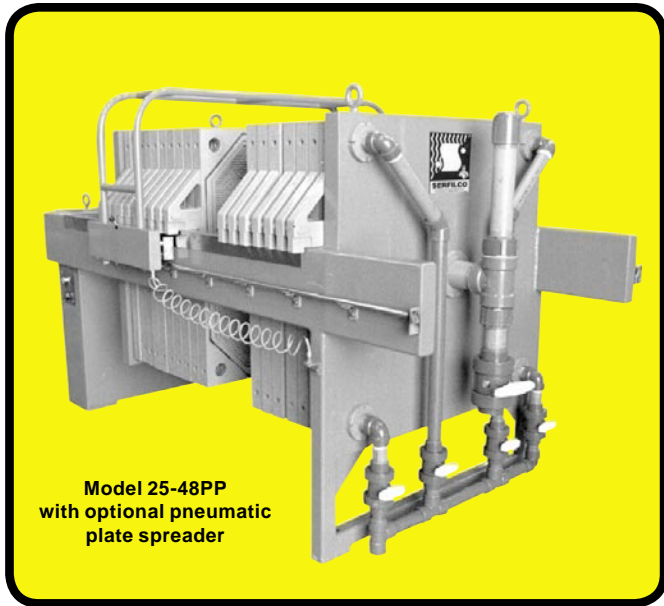

Model 25-48PP
with optional pneumatic
plate spreader

LIQUID / SOLID SEPARATION FOR:

**WASTE & SEWAGE TREATMENT
BREWING / CEMENT / CERAMIC
MINING & PLATING INDUSTRIES
FOOD & VARNISH PROCESSING
CHEMICALS**

- **MANUAL HYDRAULIC**
0.6 to 3 cu.ft.expandable
- **SEMI-AUTOMATIC**
1 to 50 cu.ft. expandable
- **AIR BLOWDOWN MANIFOLD**
- **CORROSION RESISTANT**
- **40-60% SOLIDS CONCENTRATION**
- **LOW ENERGY REQUIREMENT**
- **EASY DROPOUT CLEANING**

The Recessed Plate Filter Press will compact sludges to a dry cake with a density that is dependent upon the ultimate compaction pressure and the characteristics of the particular sludge.

Each pressload will require from 2-4 hours cycle time. To insure adequate time, the press should be sized for at least 8 hours working capacity. The table and formula below can be utilized to size your press. To confirm your sizing and evaluate the process for your application with a laboratory-sized model,

contact the Application Engineering Dept. to arrange a pilot test.

Presses feature structural steel frame, coated with tough chemical resistant epoxy paint. High density molded polypropylene filter plates are light weight and corrosion resistant. Special polypropylene quick cake release filter cloths. Air actuated hydraulic system for parting and closing the filter plates. Automatic self-compensating hydraulic system. Conveniently located operator control console.

TO SIZE YOUR PRESS, the following information is required:

SLUDGE TYPE	% OF CAKE DRY WEIGHT SOLIDS	AVERAGE DRY WEIGHT/ CUBIC FOOT
Biological Sludge	15-25	15
Metal Hydroxide Sludge	25-40	25
Lime Treated Sludge	15-60	30

- A.** Total gallons to be processed in selected press in specified period, e.g., U.S gals./8 hours. Twenty-four hours can be used to insure adequate capacity.
- B.** Percent by weight of filterable suspended solids.
- C.** Average dry weight per cubic foot for a particular sludge (obtained from table.)

CALCULATIONS:

$$\frac{A \times B \times 8.33 \text{ LBS./GAL.}}{C} \text{ OR } \frac{(\text{U.S. GALS./8 HRS.}) \times (\% \text{ SUSPENDED SOLIDS}) \times 8.33 \text{ LBS./GAL.}}{(\text{AVERAGE LBS. DRY WT./ CUBIC FT.})} = \text{CU. FT. CAPACITY FOR A DURATION}$$



TO ORDER, use Price Code Number

MANUAL HYDRAULIC												
MODEL	CUBIC FEET ¹	IN-OUT NPT & SQUARE PLATE SIZE	DIMENSIONS (IN.)						NO. OF CHAMBERS	APROX. WEIGHT (LBS.)	PRICE CODE NUMBER	
			A	B	C	D	E	F			NON-GASKETED	GASKETED
0.6-18PPMH	0.6	1½" x 1" 18½"(470mm)	32	24	49	31	37	52	4	800	43-0804	43-0804G
1-18PPMH	1.0						41	56	6	850	43-0805	43-0805G
2-18PPMH	2.0						55	70	12	940	43-0806	43-0806G
3-18PPMH	3.0						73	87	19	1060	43-0807	43-0807G
SEMI-AUTOMATIC												
1-24PP	1	2½" x 1½" 24"(610mm)	39	31	56	30	57	84	3	1700	43-0601	43-0601G
2-24PP	2						67	93	7	1900	43-0602	43-0602G
3-24PP	3						74	100	10	2050	43-0603	43-0603G
4-24PP	4						80	107	14	2150	43-0604A	43-0604AG
5-24PP	5						89	116	17	2300	43-0605A	43-0605AG
6-31PP	6	3" x 1½" 31½"(800mm)	48	40	63	30	82	109	12	4200	43-0606	43-0606G
8-31PP	8						92	119	16	4450	43-0608	43-0608G
10-31PP	10						102	129	20	4900	43-0610	43-0610G
15-31PP	15						127	154	30	5500	43-0615A	43-0615AG
20-31PP	20						152	179	40	6000	43-0620A	43-0620AG
25-48PP	25						3" x 2" 48"(1200mm)	66	58	86	35	105
30-48PP	30	116	144	25	11,850	43-0630A						43-0630AG
40-48PP	40	141	169	34	13,100	43-0640						43-0640G
50-48PP	50	163	191	42	14,000	43-0650						43-0650G

¹ Based on 1¼" thick filter cake.

NOTE: Air blowdown connections are ½" NPT on all models.

OPTIONAL EQUIPMENT

SLUDGE HOPPER

Self-dumping hoppers to transfer compacted solids from the press to a large roll-off type container. The hoppers, specifically engineered for each class of press, are easily moved with forklift truck and dumping is accomplished merely by a trip handle.

AUTOMATIC PUMP CONTROL

Allows progressively increasing air pressure on diaphragm pump to attain a denser, drier cake.

DRUM DISPOSAL SYSTEM

For presses up to 5 cubic feet. Includes chute and extended legs to raise press to permit adequate clearance for a drum.

PLATE SPREADER, SAFETY LIGHT CURTAIN, PRESS-FULL INDICATOR and HYDRAULIC INTERLOCK are additional features on some models.

DIMENSIONS

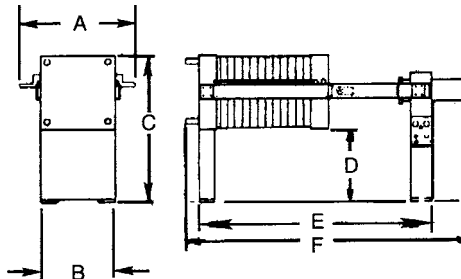

DESCRIPTION	PRICE CODE NO.
Air diaphragm pump, ½" - 14 GPM	55-7120A
Polypropylene w/nitrile 1" - 40 GPM	55-7144A
See Bulletin P-605 2" - 135 GPM	55-7208
Drum disposal system w/extended legs & carbon steel chute for 1 to 5 cu. ft. size	
Manual hydraulic 18"	43-0667
Semi-automatic 24"	43-0648
Self-dumping sludge hopper (Order 2X press capacity)	
6 cu. ft.	43-0641
10½ cu. ft.	43-0642
21 cu. ft. (Cu. ft. capacity of dumpster is 32 cu. ft. total of 2 hopper units provided)	43-0644 43-0649
PRESS-FULL indicator	43-0668

DESCRIPTION	PRICE CODE NUMBER			
	18"	24"	31"	48"
FOR PLATE SIZE	18"	24"	31"	48"
Pneu. plate spreader	-	43-0680	43-0656	43-0658
Safety light curtains	-	-	43-0659	43-0661
Replacement cloth				
Non-gasketed	SF-U18 ^T	SF-U24 ^T	SF-U31 ^T	SF-U48 ^T
Gasketed	SF-U18 ^G	SF-U24 ^G	SF-U31 ^G	SF-U48 ^G
Expander piece (For the future addition of up to 10 plates)**	43-0672	43-0673	43-0674	43-0675
Additional plates (each)	43-0676	43-0677	43-0678	43-0679
Automatic pump control				
3 stage		43-0662		
4 stage		43-0670		
Hydraulic interlock for feed pump air supply		43-0671		

Consult Application Engineering Dept. for options not shown, such as high pressure units, catwalks, drum carts, etc.

* To designate cloth position, add to Price Code Number: H Head T Tail M Intermediate

**Expander piece for maximum of 7 plates for manual hydraulic 18" size plates.



For Lab Analysis - Small Batch Production - Field Testing

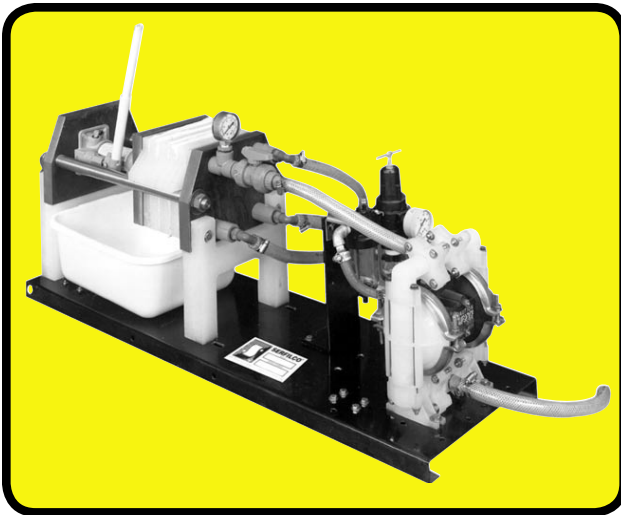

- **PLATE AND FRAME DESIGN**
Dual capacity- Can be used with one or two frames for adjusted volume - .01 cu. ft. (283 cm³) or .02 cu. ft. (566 cm³)
Area per frame - 17in² (110 cm²)
- **INCLUDES POLYPROPYLENE PLATES AND FILTER CLOTH**
Suitable for most waste solutions
- **AIR DIAPHRAGM PUMP**
Polypropylene construction
Flows adjustable to 5 GPM (15.7 LPM)
Pressure adjustable to 60 PSI (4.22 kg/cm²)

17

The **Lab Filter Press** is designed for lab analysis and small batch production. This press is also very useful for testing for upscaling to full production-size semi-automatic or manually operated presses. Includes polypropylene plates, filter cloth, air diaphragm pump, pneumatic controls, pressure gauges, inlet

flow control valve, hoses, manual hydraulic pump and drip pan. Entire assembly is mounted on a vinyl coated steel base. Flow pattern is corner inlet with three individual corner discharge lines.

TO ORDER

LAB FILTER PRESS	PRICE CODE NO.
MODEL .02 - 7PPMH	43-0857
REPLACEMENT CLOTHS (Set of 4)	PRICE CODE NO.
SF - 7 x 7	43-0822

Dimensions: 42" (1.1m) L x 13" (.33m) W x 22" (.56m) H
Shipping Weight: 95 Lbs (43 kg.)
Maximum operating temperature: 150° F (66° C)

