



DRUM PUMPS



Drums & Barrels



Large Storage Vessels



Small Storage Vessels

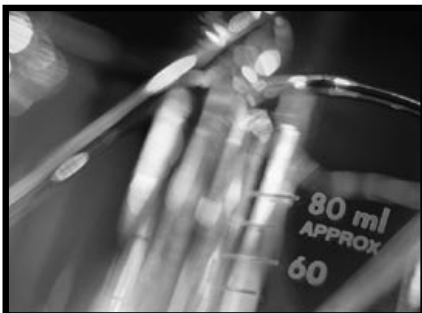

Laboratory

A COMPLETE PRODUCT LINE OF PUMPS FOR FAST, SAFE AND CONVENIENT TRANSFER AND DISPENSING OF LIQUIDS.

- Provides easy transfer of almost any liquid including viscous products.
- Choice of materials of construction for chemical compatibility.
- Choice of pump lengths depending on drum, barrel or storage vessel size.
- Choice of air or electric motor drives.
- Batch control for dispensing present volumes of liquid.
- Measure flow rate and volume with resettable totalizer.

SERIES 'DP' DRUM PUMPS

For chemically aggressive liquids such as acids, alkalies and salt solutions as well as most solvents and organic acids.

HIGH VISCOSITY DRUM PUMPS

- **SANITARY**
For food processing, pharmaceutical, biotechnology and cosmetic industries
- **INDUSTRIAL**
For polymers, paints, resins, adhesives and petroleum products

SMART DRUM PUMP

Batch and flow control systems



SERIES 'DP' DRUM PUMPS

47

P-402AD



FAST, SAFE AND CONVENIENT DISPENSING OF LIQUIDS.

- Superior quality materials and state-of-the-art manufacturing techniques with proven reliable design features.
- Made in the U.S.A.
- **PUMP TUBES**
 - Pump available in polypropylene, PPP high temperature polypro, CPVC, pure PVDF or 316 stainless steel.
 - Lengths of 27", 39", 47", 60" and 72".
 - Seal-less, one-piece outer tube with screw-on "foot".
No weak spin welds or glued components.
 - Easy on-site service. No special tools required.
- **MOTORS**
 - Heavy duty 1.1 HP electric motors (open or TEFC) with variable speed control for precise delivery without splashback.
 - Economy 450 watt motor.
 - Explosion-proof and air driven motors

SERIES 'DP' Drum Pumps combine modern manufacturing techniques with proven and reliable design features. They are a convenient and efficient means of transferring and dispensing most liquid chemicals from drums, carboys and tanks.

These pumps are available in a selection of engineered plastics or polished 316 stainless steel thus providing a great range of chemical compatibility.

The pumps are available in lengths to meet your requirements and all pumps can be used interchange-

ably with any of our electric or air motors. They can be quickly changed to meet particular pumping or motor requirements.

Simply insert the pump into the liquid for immediate pumping. No priming is necessary since the rotor is located at the bottom end of the pump. Flow may be controlled with the unique speed control knob on the ODP-S and ENC-S motors to prevent splashing and control the volume. Keep these handy pumps on location throughout your plant for convenient solution transfer.



Drums & Barrels



Laboratory



Large Storage Vessels

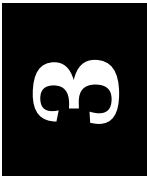



DRUM PUMP TUBES

P-402AD

Pump tubes are designed with threaded joints for easy maintenance and individual component replacement without special tools. Our guide sleeves are PTFE, with a specially extruded fin which secures it inside the inner tube.

We utilize a seal grade carbon for our lower bushing (pure carbon 6038C), the most chemically resistant carbon available. Our shafts are Hastelloy® C-276 (PP, PPP, CK and KY models), or 316 stainless steel (SS models).

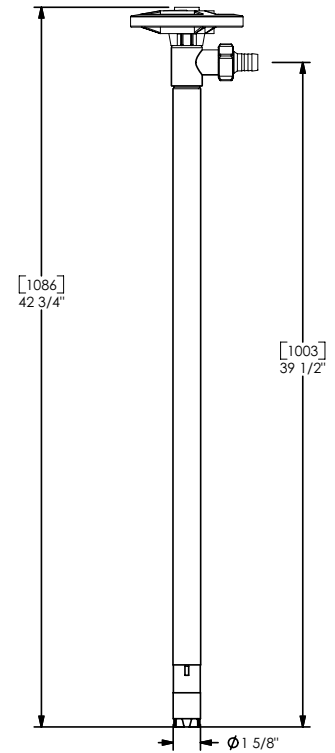
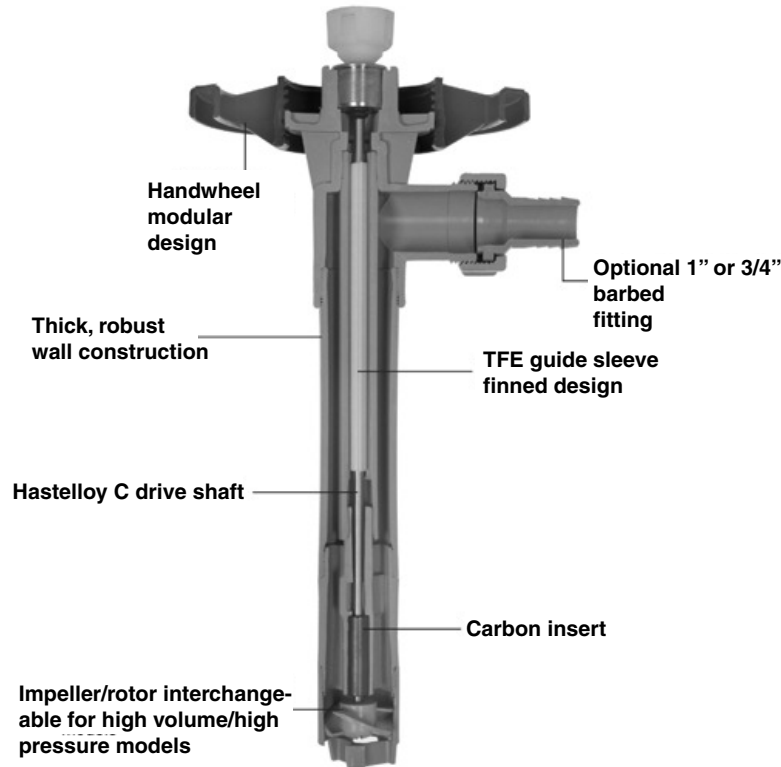

Empties a 55 U.S. gallon (200L) drum in less than 2 minutes.

Design: Seal-less / Centrifugal

Discharge Options: 1" (25mm) barb
3/4" (22mm) barb

Viscosity: 1500 Cps/mPas (ODP-S, ENC-S)
750 Cps/mPas (ODP450,
EXP-UL, AIR (F))
450 Cps/mPas (AIR (B))

**Maximum
Specific Gravity:** 1.8



SAFETY PRECAUTIONS

Verify the chemical compatibility of the material of your pump with the liquid you are pumping. Never use a pump that is not chemically compatible with the fluids you are pumping or serious bodily harm, fire or explosion could result.

The high velocity flow of liquid through a pump could create static electricity. All pumps and containers must be properly grounded and bonded to prevent static discharge and sparking, which could cause electric shock, fire or explosion.

A ground wire should be used on any explosion-proof motor as well as the container when transferring explosive material. This warning pertains to electric and pneumatic motors.

Only metallic pumps should be used for transferring flammable or explosive liquids. Do not pump an explosive or flammable liquid with ODP, ENC, Air (B) or Air (F) motors.

Follow all safety recommendations regarding clothing and goggles, which should be worn when using these pumps.

TO ORDER, use Price Code Number

PP POLYPROPYLENE

APPLICATIONS:

Most chemically aggressive liquids such as acids, salt solutions and solutions which corrode or oxidize metals, such as hydrofluoric or sulfuric acid.

Maximum liquid temperature 130°F (54°C).

⚠ Not for use with flammable liquids.

PUMP MODEL NUMBER*	PRICE CODE NUMBER*	MATERIALS OF CONSTRUCTION	LENGTH	DIA.	FOR HOSE SIZE**
PP8327-1	52-1008	Polypropylene w/Hastelloy® C276, PTFE, carbon	27" (690 mm)	1-5/8" (41mm)	1"
PP8339-1	52-1000		39" (1000 mm)		
PP8347-1	52-1001		47" (1200 mm)		
PP8360-1	52-1003		60" (1525 mm)		
PP8372-1	52-1005		72" (1825 mm)		

PPP HIGH TEMPERATURE POLYPROPYLENE APPLICATIONS:

Engineered for transferring high temperature corrosive liquids. Robust PPP polypropylene ensures chemical resistance and excellent heat deflection against light and mildly aggressive liquids.

Maximum liquid temperature 175°F (80°C).

⚠ Not for use with flammable liquids.

PUMP MODEL NUMBER*	PRICE CODE NUMBER*	MATERIALS OF CONSTRUCTION	LENGTH	DIA.	FOR HOSE SIZE**
PPP8327-1	52-6000	High temperature Polypropylene w/Hastelloy® C276, PTFE, carbon	27" (690 mm)	1-5/8" (41mm)	1"
PPP8339-1	52-6001		39" (1000 mm)		
PPP8347-1	52-6002		47" (1200 mm)		
PPP8360-1	52-6003		60" (1525 mm)		
PPP8372-1	52-6004		72" (1825 mm)		

CK CPVC / PVDF APPLICATIONS:

Used for pumping aggressive solutions such as sodium hypochlorite or for higher temperature applications where polypropylene is not suitable.

Maximum liquid temperature 190°F (90°C).

⚠ Not for use with flammable liquids.

PUMP MODEL NUMBER*	PRICE CODE NUMBER*	MATERIALS OF CONSTRUCTION	LENGTH	DIA.	FOR HOSE SIZE**
CK8327-1	52-5200	CPVC and PVDF w/Hastelloy® C276, PTFE, carbon	27" (690 mm)	1-5/8" (41mm)	1"
CK8339-1	52-5201		39" (1000 mm)		
CK8347-1	52-5202		47" (1200 mm)		
CK8360-1	52-5203		60" (1525 mm)		
CK8372-1	52-5204		72" (1825 mm)		

KY PVDF APPLICATIONS:

Capable of pumping highly aggressive solutions which are not compatible with other thermoplastics.

Maximum liquid temperature 180°F (82°C).

⚠ Not for use with flammable liquids.

PUMP MODEL NUMBER*	PRICE CODE NUMBER*	MATERIALS OF CONSTRUCTION	LENGTH	DIA.	FOR HOSE SIZE**
KY8327-1	52-4004	Natural PVDF w/Hastelloy® C276, PTFE, carbon	27" (690 mm)	1-5/8" (41mm)	1"
KY8339-1	52-4000		39" (1000 mm)		
KY8347-1	52-4001		47" (1200 mm)		

SS 316 STAINLESS STEEL APPLICATIONS:

Most solvents and organic acids, as well as salt solutions, nitrous acids, dyes, all alkalis, potable liquids to 200°F (93°C). All components are polished for a quality finish.

Maximum liquid temperature 180°F (82°C).

⚠ For use with flammable or explosive liquids.

PUMP MODEL NUMBER*	PRICE CODE NUMBER*	MATERIALS OF CONSTRUCTION	LENGTH	DIA.	FOR HOSE SIZE**
SS8339-1	52-2000	316 stainless steel, PTFE, carbon	39" (1000 mm)	1-5/8" (41mm)	1"
SS8347-1	52-2001		47" (1200 mm)		
SS8360-1	52-2002		60" (1525 mm)		
SS8372-1	52-2003		72" (1825 mm)		

* For high head pump – Add **H** to Model Number and Price Code No.

** for 3/4" hose connections, see Accessories on page 6.

All pumps are provided with a 1" stainless steel hose clamp. Stainless steel models also include bonding and grounding cables.

Registered trademarks:

Viton - **DuPont Dow Elastomers**; Teflon - **DuPont**;
Hastelloy - **Haynes, International**

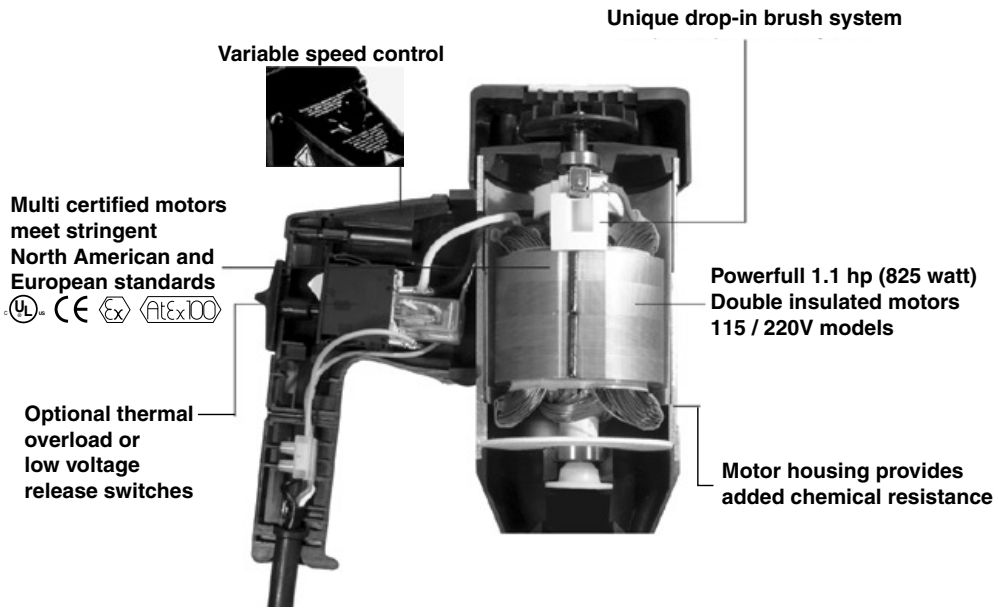
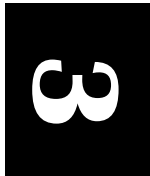

TO ORDER, use Price Code Number

All motors are rated for continuous duty with the specific gravities listed. They are acceptable for intermittent service on higher specific gravity liquids.

ODP-450



ODP 450 OPEN DRIP-PROOF MOTOR

0.6 HP (450 watts). Drip proof motor in rugged glass reinforced plastic housing. Engineered for in corrosive environments. Includes 16 ft cord w/molded plug. Not suitable for hazardous duty. For viscosities up to 750 cps or specific gravity up to 1.8 weight.

MODEL NO.	PRICE CODE NO.	MOTOR VOLTAGE
ODP450-115	52-8008	115V/1/50-60
ODP450-240	52-8009	230-240V/1/50-60

Not for use with flammable liquids.

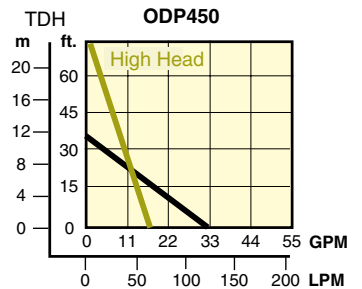

ODP-S



ODP-S OPEN DRIP-PROOF MOTOR w/speed control

1.1 HP (825 watts). Drip-proof motor in rugged glass reinforced plastic housing. Speed control knob allows for efficient, controlled liquid dispensing. ON/OFF switch conveniently located for single hand, thumb control. Resettable thermal overload protected, double insulated motor. Cartridge brush design extends life and greatly reduces replacement service time. Includes 16 ft. cord w/molded plug. Not suitable for hazardous duty. For viscosities up to 1500 cps or specific gravity up to 1.8. Weight: 8.8 lbs. (4 kg.)

MODEL NO.	PRICE CODE NO.	MOTOR VOLTAGE
ODP-S-115	52-8000	115V/1/50-60
ODP-S-240	52-8001	230-240V/1/50-60

Not for use with flammable liquids.

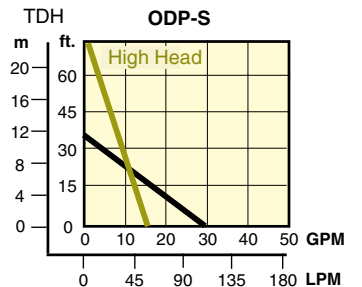

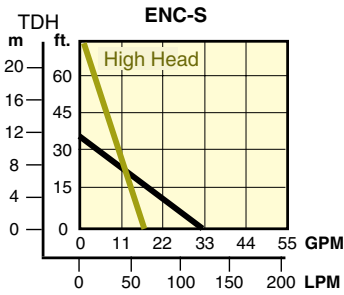

ENC-S SEVERE DUTY TOTALLY ENCLOSED MOTOR w/speed control

1.1 HP (825 watts). Totally enclosed motor in anodized aluminum housing for extra protection. Speed control knob allows for efficient, controlled liquid dispensing. ON/OFF switch conveniently located for single hand, thumb control. Resettable thermal overload protected, double insulated motor. Cartridge brush design extends life and greatly reduces replacement service time. Includes 16 ft. cord w/molded plug. For viscosities to 1500 cps or specific gravity up to 1.8. Not suitable for hazardous duty. Weight: 12 lbs. (6 kg.)

MODEL NO.	PRICE CODE NO.	MOTOR VOLTAGE
ENC-S-115	52-3000	115V/1/50-60
ENC-S-240	52-3001	220-240V/1/50-60

Not for use with flammable liquids.

ENC-S

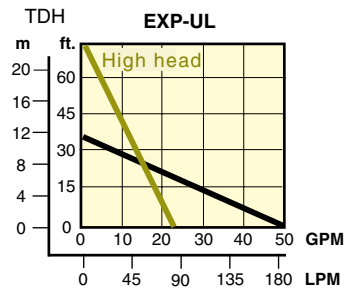
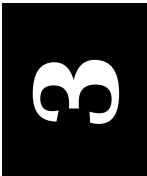

EXP-UL EXPLOSION-PROOF MOTOR

.83 HP (620 watts)**. Explosion-proof motor in aluminum housing. C.S.A. and U.L. listed Class I, Groups C and D. Thermal overload protected, automatic reset. Includes 16 ft. cord, no plug. For viscosities up to 750 cps or specific gravity up to 1.8. Includes grounding cable. Weight: 20 lbs. (9.5 kg.)

MODEL NO.	PRICE CODE NO.	MOTOR VOLTAGE
EXC-UL-115	55-0744	115V/1/50-60
EN5-240*	55-7167	220-240V/1/50

* Protection class (PTB): EE_x de 11C T6

** 620 watt input / 430 watt output

For flammable or explosive liquids.

EXP-UL

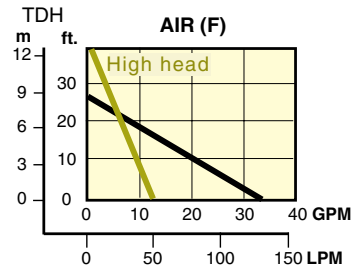

AIR (F) AIR DRIVEN MOTOR

.73 HP (550 watts), 28 cu. ft./min. @ 90 PSI, 10,000 RPM. Aluminum motor housing is plastisol coated to prevent sparking. Includes muffler, filter, and trigger valve for flow control. For viscosities to 750 cps or specific gravity to 1.75. Air line filter, PSI regulator and automatic oiler recommended. Weight: 3.5 lbs. (1.6 kg.)

MODEL NO.	PRICE CODE NO.
AIR (F)	52-0100

Not for use with flammable liquids.***

AIR (F)

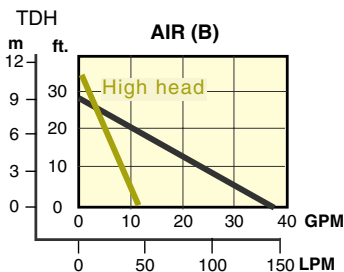

AIR (B) AIR DRIVEN MOTOR

.5 HP (370), 22 cu. ft./min. @ 90 PSI, 10,000 RPM. Aluminum motor housing, glass reinforced plastic pump mounting bracket. Not suitable for hazardous duty. For viscosities to 450 cps or specific gravity up to 1.6. Muffler included. When air supply line is fitted with an optional regulator, the pump output can be precisely controlled. Weight: 3 lbs. (1.4 kg.)

MODEL NO.	PRICE CODE NO.
AIR (B)	55-0701

Not for use with flammable liquids.***

AIR (B)



*** CAUTION: Air motors are not recognized under any current Underwriters' Laboratory listing program. Consult a qualified safety engineer for suitability for use in a hazardous area or with flammables.



Everything you need for safe and efficient liquid transfer

PACKAGE 1
Water Treatment
Chemicals

Engineered to transfer corrosive chemicals associated with the water treatment industry. Common applications include: Sodium Hypochlorite, Potassium Hydroxide and Sodium Bromide.

Motor type: ODP-S
 Pump assembly: CPVC
 Pump length: 39"(1000 mm)
 PVC hose: 6 ft. (1.8 m), I.D. 1" (25 mm)
 Dispensing nozzle: 1" (25 mm), polypropylene
 Barrel adapter: Polypropylene
 Storage bracket: 16 gauge coated steel
 Max. viscosity: 1500 CPS / Mpas
 Max. temperature: 190°F(90°C)

PRICE CODE NO.	VOLTAGE
52-9430	115V
52-9431	240V



PACKAGE 2
Acids & Alkalies

Engineered to transfer mildly corrosive liquids. Common applications include: Hydrochloric Acid, Nitric Acid - 20%, Acetic Acid and Sulfuric Acid

Motor type: ODP-S
 Pump assembly: Polypropylene
 Pump length: 39"(1000 mm)
 PVC hose: 6 ft. (1.8 m), I.D. 1" (25 mm)
 Dispensing nozzle: 1" (25 mm), polypropylene
 Barrel adapter: Polypropylene
 Storage bracket: 16 gauge coated steel
 Max. viscosity: 1500 CPS / Mpas
 Max. temperature: 130°F(55°C)

PRICE CODE NO.	VOLTAGE
52-9400	115V
52-9401	240V

PACKAGE 3
Concentrated
Acid & Alkalies

Engineered for transferring very concentrated and extremely aggressive liquids. Common applications include: Sulfuric Acid 66 Baume, Propionic Acid, Concentrated Nitric - 98% and Hydrofluoric Acid.

Motor type: ENC-S
 Pump assembly: PVDF
 Pump length: 39"(1000 mm)
 PVC hose: 6 ft. (1.8 m), I.D. 1" (25 mm)
 Dispensing nozzle: 1" (25 mm), PVDF
 Barrel adapter: Polypropylene
 Storage bracket: 16 gauge coated steel
 Max. viscosity: 1500 CPS / Mpas
 Max. temperature: 175°F(80°C)

PRICE CODE NO.	VOLTAGE
52-9420	115V
52-9421	240V

Unique design allows users to safely measure and transfer mildly corrosive liquids. Common applications include: Hydrochloric Acid, Nitric Acid - 20%, Acetic Acid and Sulfuric Acid.

Motor type: ODP-S
 Pump assembly: Polypropylene
 Pump length: 39"(1000 mm)
 PVC hose: 6 ft. (1.8 m), I.D. 1" (25 mm)
 Dispensing nozzle: 1" (25 mm), polypropylene
 Flow meter: Digital / polypropylene totalizer
 Barrel adapter: Polypropylene
 Storage bracket: 16 gauge coated steel
 Max. viscosity: 300 CPS / Mpas
 Max. temperature: 130°F(55°C)

PRICE CODE NO.	VOLTAGE
52-9500	115V
52-9501	240V

PACKAGE 4
MEASUREMENT
Acid & Alkalies

Unique design allows operators to safely measure and transfer concentrated and very aggressive liquids. Common applications include: Sulfuric Acid 66 Baume, Propionic Acid, Concentrated Nitric - 98 and Hydrofluoric Acid.

Motor type: ENC-S
 Pump assembly: PVDF (Kynar®)
 Pump length: 39"(1000 mm)
 PVC hose: 6 ft. (1.8 m), I.D. 1" (25 mm)
 Dispensing nozzle: 1" (25 mm), PVDF
 Flow meter: Digital / PVDF totalizer
 Barrel adapter: Polypropylene
 Storage bracket: 16 gauge coated steel
 Max. viscosity: 300 CPS / Mpas
 Max. temperature: 175°F(80°C)

PRICE CODE NO.	VOLTAGE
52-9510	115V
52-9511	240V

PACKAGE 5
MEASUREMENT
Concentrated
Acid & Alkalies





LABORATORY DRUM PUMP

- Ideal for low volume transfer
- Polypropylene
- 27" or 39" length

Versatile, lightweight pump for the transfer of acids or alkalis from glass carboys and similar containers. Pump will handle liquids to 250 cps. Motor is 160 watt with built-in overload and manual reset for safety. Includes 16' cord with molded plug, 10' of 1/2" vinyl hose, polypropylene flow nozzle & wall bracket.

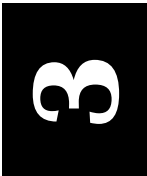
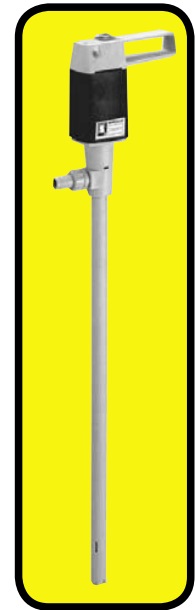
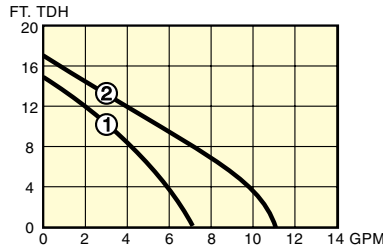

TO ORDER, use Price Code No.

MODEL NO.	PRICE CODE NO.	CURVE	MATERIALS OF CONSTRUCTION	LENGTH	DIA.	HOSE SIZE	MAX. TEMP.	160 WATT MOTOR	WEIGHT
				inches	inches	inches	°F		Lbs.
PP8327-1-115	55-9000	2	Carbon Viton®	27	1	1/2 - 3/4	115	115V/1/60	9.5
PP8327-2-110	55-9001	2			1 1/4			110V/1/50-60	
PP8327-2-220	55-9002	1			1 1/4			220V/1/50-60	
PP8339-1-110	55-9003	1	Ceramic ETFE Hastelloy®C	39	1	1/2 - 3/4	115	110V/1/50-60	10
PP8339-1-220	55-9004	2			1			220V/1/50-60	
PP8339-2-110	55-9005	2			1 1/4			110V/1/50-60	
PP8339-2-220	55-9006	2			1 1/4			220V/1/50-60	

ACCESSORIES

GROUND-BOND CABLE

When pumping flammable or combustible liquids from one container to another, both containers must be effectively bonded and grounded to prevent discharge of sparks of static electricity which could cause an explosion. Not for use with plastic pumps or ODP/ENC motors.

- 2 ground cables, 6' long with clamps.....
- 1 bond cable, 10' long with clamps.....
- 1 ground cable, 1' long with clamp for drum.....

PRICE CODE NO.	
55-0246	
55-0245	
55-0299	

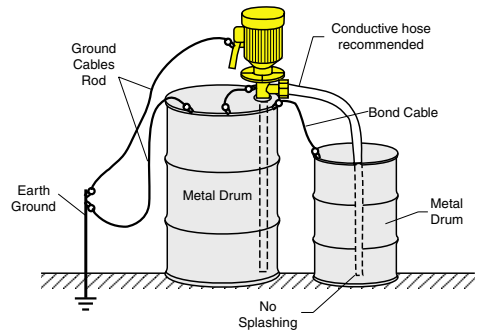

316 SS SQUEEZE CLAMP WITH HOSE CLAMP

To securely hold discharge hose or nozzle to tank flange or container while operating. Holds hose to wall bracket for storage. Prevents spillage and siphoning. Entire assembly is 316 stainless steel and hose clamp is welded onto hand clamp. Ends of clamp have a lip to grip drum flange.



FOR HOSE SIZE I.D.	FORCE TO OPEN		SIZE	PRICE CODE NO.
1/2" TO 1"	12 lbs.	5.5 kg.	Small - 4.5" handle	99-0190 A
1" TO 1 1/2"	22 lbs.	10 kg.	Large - 7.0" handle	99-0191 A



Increase the functional use of any drum pump

HOSE, CLAMPS & HOSE BARBS

	PRICE CODE NO.
PVC HOSE - CLEAR - 3/4" I.D. - per foot.....	55-0266
1" I.D. - per foot.....	55-0274
NYLON REINFORCED HOSE - CLEAR 3/4" I.D. - per foot.....	22-0481
1" I.D. - per foot.....	22-0432
STAINLESS STEEL FLEXIBLE HOSE - 3/4" NPT x 8' long (male x female).....	22-0539A
PTFE RIBBED HOSE - 1" I.D. x 8' long	22-0463
HOSE CLAMP - 3/4" stainless steel.....	22-0520
1" stainless steel.....	22-0505
DISCHARGE HOSE BARB - 3/4" polypropylene.....	52-1051
3/4" PVDF.....	52-4051
DISCHARGE ADAPTER - 3/4" MNPT, CPVC.....	55-6096
3/4" MNPT, 316 SS.....	55-6095
1" MNPT, 316 SS.....	55-6100
CHECK VALVE - 3/4" FNPT, PVC.....	33-6051

STRAINER

Recommended when pumping dirty liquids or where abrasive particles are present.

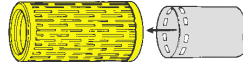

NOZZLE

Provides controlled dispensing of liquid without splashing for safe chemical transfer.

Ideal for dispensing into small containers, the nozzle features full one inch flow-through for maximum flow and allows hand held squeeze control for corrosive applications.

1" hose barb connection.

**WALL BRACKET -
black vinyl coated 16 ga. steel**

A wall bracket is recommended for every pump. Proper storage will increase the life of the unit.

PRICE CODE NO.
55-0265

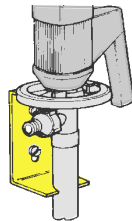

BARREL ADAPTERS / FUME BARRIER

For all pump models. To hold pump in vertical position and avoid exposure of motor to escaping vapors. Snug slip fit over pump tube allows for depth adjustment in drum.

Fume barrier utilizes a Viton seal to hold corrosive fumes within the container.

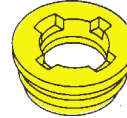

SS, 2" NPT, for metal drum pumps.....

PP, 2" NPT, for polypropylene, PVDF and metal drum pumps.....

PP, 2" buttress thread, for polypropylene and PVDF drum pumps.....

Fume barrier, stainless steel, 2" NPT.....

Fume barrier, polypropylene, 2" NPT.....

PRICE CODE NO.
99-0157
99-0107A
99-0108A
52-9019
52-9018

PP for PP or PVDF pumps.....
SS for SS pumps.....

PRICE CODE NO.
55-0282A
55-0283A



Polypropylene, Viton® and Hastelloy (shaft and spring).....

Stainless steel and Teflon®.....

PVDF.....

PRICE CODE NO.
52-0017
52-0017S
52-0017K

AIR FILTER/REGULATOR/LUBRICATOR

To protect all air driven motors, with polycarbonate bowl & pressure gauge (200 psi), 3/8" NPT

PRICE CODE NO.
55-1142

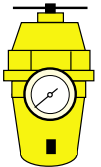



SMART DRUM PUMP BATCH CONTROL SYSTEM

55

P-412



**CHEMICAL PACKAGING / PLATING
WASTE WATER TREATMENT
CHEMICAL MANUFACTURING
SEMI-CONDUCTOR
PHARMACEUTICAL / AGRICULTURE**

Dispenses liquids:

- safely
- accurately – preset volume
- easily
 - push to start
 - shuts off automatically

SERFILCO Smart Pumps are engineered to control, measure and dispense any volume of liquid from drums, IBCs, tanks and any large storage vessel. They can be used in any industry where batching, chemical packaging or dilution is required to be accurate and efficient.

OPERATION

Simply enter the desired volume of liquid with directional arrows. Press ENTER and the SERFILCO Smart Pump Batch Control System engages the motor, dispenses the required volume, then stops the motor to complete the process. Motor speed control is also included to dispense at the desired flow rate.

ADVANTAGES

- Accuracy – within 0.5%. Meter employs “Teach In” calibration or preset “K factors” for various specific gravities. No more estimating or using floor scales to properly measure corrosive chemicals.
- Safety – operator does not come in contact with corrosive chemicals. No more drum tilting with fork lifts, measurement with buckets or pails. Control transfer of highly corrosive liquids from your storage container to a mixing tank or process line.
- Memory – Save up to 7 preset volumes in the Automatic Batch memory or change each batch in the Manual Batch setting.
- Versatility –
 1. Displays volume units in gallons, Imperial gallons, liters, milliliters or cubic meters.
 2. Displays flow rate in gallons, Imperial gallons, liters, milliliters or cubic meters per minute, second, or hour.
 3. Language can be displayed in English, German, French, Italian or Spanish, as desired.
 4. Available in PP or PVDF for complete chemical compatibility.
 5. Available with standard pump tube lengths for : carboys – 27” (700 mm), drum – 39” (1000 mm), tanks – 47” (1200 mm), IBCs – 60” (1500 mm) and large storage vessels – 72” (1600 mm).
 6. Batch Controller operates on 120V or 220V power.
 7. Smart Motors are available in TEFC or ODP for any corrosive environment. Both 60 Hz and 50 Hz motors are available.
- Efficient – system operates up to 25 GPM. Faster transfer and measurement of liquid increases productivity and lowers downtime.
- Quick connection – 1” hose barb or 1” NPT thread for ease in hose change or quick disconnect setup.

3



SMART DRUM PUMP BATCH CONTROL SYSTEM

- Maximum temperature – 175°F (80° C)
- Suction dimension – 1.63" (41 mm)
- Maximum viscosity – 300 cps
- Maximum flow – 25 GPM (95 l/min)
- Maximum specific gravity – 1.89
- Discharge dimension – 1" (25.4 mm) hose barb or NPT thread

SYSTEM MODEL NUMBER	MOTOR	PUMP TUBE MATERIAL - LENGTH	METER, WETTED COMPONENTS	PRICE CODE NO.
PP-BC-ODP-27 PP-BC-ODP-39 PP-BC-ODP-47 PP-BC-ODP-60 PP-BC-ODP-72	ODP-115V / 1 / 60 Hz	PP-27" PP-39" PP-47" PP-60" PP-72"	PP, ceramic	52-0200 52-0201 52-0202 52-0203 52-0204
PP-BC2-ODP-27 PP-BC2-ODP-39 PP-BC2-ODP-47 PP-BC2-ODP-60 PP-BC2-ODP-72	ODP-220V / 1 / 50 Hz	PP-27" PP-39" PP-47" PP-60" PP-72"	PP, ceramic	52-0210 52-0211 52-0212 52-0213 52-0214
PP-BC-ENC-27 PP-BC-ENC-39 PP-BC-ENC-47 PP-BC-ENC-60 PP-BC-ENC-72	TEFC-115V / 1 / 60 Hz	PP-27" PP-39" PP-47" PP-60" PP-72"	PP, ceramic	52-0220 52-0221 52-0222 52-0223 52-0224
PP-BC2-ENC-27 PP-BC2-ENC-39 PP-BC2-ENC-47 PP-BC2-ENC-60 PP-BC2-ENC-72	TEFC-220V / 1 / 50 Hz	PP-27" PP-39" PP-47" PP-60" PP-72"	PP, ceramic	52-0230 52-0231 52-0232 52-0233 52-0234
KY-BC-ENC-27 KY-BC-ENC-39 KY-BC-ENC-47	TEFC-115V / 1 / 60 Hz	PVDF-27" PVDF-39" PVDF-47"	PVDF, ceramic	52-0240 52-0241 52-0242
KY-BC2-ENC-27 KY-BC2-ENC-39 KY-BC2-ENC-47	TEFC-220V / 1 / 50 Hz	PVDF-27" PVDF-39" PVDF-47"	PVDF, ceramic	52-0250 52-0251 52-0252
KY-BC-ODP-27 KY-BC-ODP-39 KY-BC-ODP-47	ODP-115V / 1 / 60 Hz	PVDF-27" PVDF-39" PVDF-47"	PVDF, ceramic	52-0260 52-0261 52-0262
KY-BC2-ODP-27 KY-BC2-ODP-39 KY-BC2-ODP-47	ODP-220V / 1 / 50 Hz	PVDF-27" PVDF-39" PVDF-47"	PVDF, ceramic	52-0270 52-0271 52-0272

*SYSTEM INCLUDES 1 EACH: SERFILCO drum pump Smart Motor, pump tube and batch controller with all necessary connections.



MODEL SE35 BATTERY POWERED DIGITAL FLOW METER / TOTALIZER



SERFILCO Model SE35 Digital Flow Meters utilize proven paddle wheel design for greater accuracy when measuring low to medium viscosity liquids. The separate flow chamber and removable electronic module provide maximum chemical resistance to meet the toughest applications. Nema 4 (IP65) enclosure. Measuring range 2-200 GPM (7.5 - 757 LPM). Temperature range 32°F - 217°F (0°C - 100°C).

FLOW METER KITS

Flow meter and flow chamber with discharge nozzle and 1" hose barb inlet.

FLOW METERS

Flow meter and flow chamber with 1" hose barb inlet & outlet.

- Separate flow chamber and electric module with unique "1/4 Turn & Lock" connect system.
- Measure flow rate and volume with resettable totalizer.
- Menu – guided user friendly operating system allows for customized setting. Equipped with E Eprom electronics.
- Accuracy 0.5%, 0.4% repeatability.
- 9V – Lithium Battery.

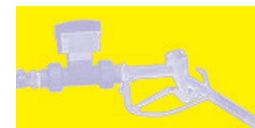

FLOW METERS KITS

MODEL NO.	WEITED MATERIALS	PRICE CODE NO.
SE35PP-KIT	PP, PVDF, ceramic	52-0160
SE35KY-KIT	PVDF, ceramic	52-0161
SE35SS-KIT	316 SS, PVDF, ceramic	52-0162

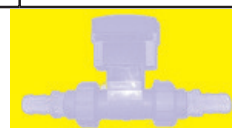

FLOW METERS

MODEL NO.	WETTED MATERIALS	PRICE CODE NO.
SE35PP-B	PP, PVDF, ceramic	52-0170
SE35KY-B	PVDF, ceramic	52-0171
SE35SS-B	316 SS, PVDF, ceramic	52-0172

BATTERY POWERED ELECTRONIC FLOW METER



- Self-contained microprocessor with LCD readout
- + 1.5% accuracy, + 0.3% repeatability
- Measures flow rate and total flow separately
Consult Sales Dept. for other registers.
- 316 stainless steel, nylon or PVDF
- Factory calibrated: 3 - 50 U.S. GPM or 10 - 190 LPM

SERFILCO Electronic Digital Flow Meters combine microprocessor technology with rugged and accurate turbine flow sensor design. Power is supplied by 2 lithium batteries (included) that provide an average 2,000 hours of intermittent use. LCD display automatically turns on when flow starts and off four minutes after flow ceases. Standard connection is 1" NPT. All electronics are enclosed under splash-tight gasketed acrylic cover. Pressure drop 2 psig @ 30 GPM (1.4 BAR @ 114 LPM) and 5 psig @ 50 GPM (3.5 BAR @ 190 LPM). Dimensions: 4" x 2.5" x 2" (10.2 x 6.4 x 5.1 cm)

MODEL NO.	WETTED MATERIALS	PRICE CODE NO.
DMSS-1	Stainless steel, PVDF, ferrite, ceramic	52-0998 G
DMN-1	Nylon, ferrite, ceramic, stainless steel	52-0999 G
DMKY-1	PVDF, ceramic	52-0994 G

For LPM calibration change **G** to **L** in Price Code Number



HIGH VISCOSITY DRUM PUMPS



INDUSTRIAL & SANITARY PUMP SERIES

- Flows to 17 GPM / 64 LPM
- Max Pressure 174 psi / 12 bar
- Rugged construction
All 316 stainless steel
Choice of stator elastomers
- Industrial Series 700 or Sanitary Series 800
 - Speed Reduced pump (SR)
Max viscosity 25,000 cps/mPas
 - Direct Drive pump (DD)
Max viscosity 100,000 cps/mPas



Progressive Cavity Design

SERFILCO Progressive Cavity pumps are engineered to transfer high viscosity materials from drums, tanks and IBC's. Utilizing the principle of positive displacement, these pumps deliver a continuous flow with little product degradation. The series 700 (Industrial) and series 800 (Sanitary) pumps can transfer materials ranging in viscosity up to 100,000 cps/ mPas. All pumps are constructed from robust 316SS with a choice of stator elastomers.

Series 700 Industrial Pump

SERFILCO series 700 Industrial Pumps are commonly used throughout the industrial marketplace for trans-

ferring viscous materials such as polymers, paints, resins, adhesives and petroleum based products.

Series 800 Sanitary Pump

SERFILCO series 800 Sanitary Pumps are commonly used throughout the sanitary food processing, pharmaceutical, biotechnology, and cosmetic industries. Applications include the transfer of tomato paste, mayonnaise, pie fillings, salad dressing, shampoos, and cosmetic lotions. The series 800 pumps are manufactured according to Δ standards with FDA approved materials of construction. The pumps utilize a threaded design and tri-clamp fittings for quick cleaning, inspection and maintenance.



PAINTS



PHARMACEUTICAL



COSMETICS



PETROLEUM

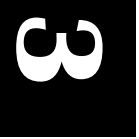



Technical Data

Max. Viscosity: 25,000cps (mPAS)
Discharge Port: 1.5" / 38mm hose barb, optional 1.25" / 32mm
Wetted Material: Tube & Rotor Assembly: 316 Stainless Steel
 Stator Material: See below
Mechanical Seal: SiC/Viton/SiC
Motor Drives: ODP450, ODP-S, ENC-S, EXP-UL, AIR(F)
Fittings: Large Type Acme Thread design enables quick disassembly for cleaning and maintenance.



SR 700 Industrial Pump Series

- Easy Maintenance
- Threaded Components
- Interchangeable Motors Drives
- Continuous Flow
- Low Shearing Properties

MODEL NUMBER	PRICE CODE NO.	FLOW RATE**	MAX PRESSURE	PUMP LENGTH
SR700-71-27-*	52-7700*	7 GPM	87 PSI	27"
SR700-71-39-*	52-7703*			39"
SR700-71-47-*	52-7706*			47"
SR700-72-27-*	52-7701*	7 GPM	174 PSI	33"
SR700-72-39-*	52-7704*			45"
SR700-72-47-*	52-7707*			53"
SR700-181-27-*	52-7702*	17 GPM	87 PSI	27"
SR700-181-39-*	52-7705*			39"
SR700-181-47-*	52-7708*			47"

* Add to Model No. and Price Code No. ** Based on water
 B for Buna-N
 T for PTFE
 V for Viton



SR 800 Sanitary Series



- Hygienic Design
- Easy to Clean & Maintain
- Gentle Product Treatment
- Continuous Flow

MODEL NUMBER	PRICE CODE NO.	FLOW RATE**	MAX PRESSURE	PUMP LENGTH
SR800-71-27-*	52-7800*	7 GPM	87 PSI	27"
SR800-71-39-*	52-7803*			39"
SR800-71-47-*	52-7806*			47"
SR800-72-27-*	52-7801*	7 GPM	174 PSI	33"
SR800-72-39-*	52-7804*			45"
SR800-72-47-*	52-7807*			53"
SR800-181-27-*	52-7802*	17 GPM	87 PSI	27"
SR800-181-39-*	52-7805*			39"
SR800-181-47-*	52-7808*			47"

* Add to Model No. and Price Code No. ** Based on water
 FG for food grade Buna
 T for PTFE

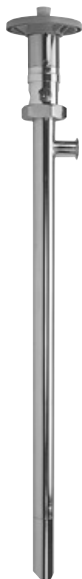

Warning: When pumping flammable or combustible liquids pump tube must be used in conjunction with an explosion proof motor



SR 700 & SR 800 PUMP MOTORS

P-411A

ODP450



ODP 450 OPEN DRIP-PROOF MOTOR

0.6 HP (450 watts). Drip proof motor in rugged glass reinforced plastic housing. Engineered for in corrosive environments. Includes 16 ft cord w/molded plug.

Weight: 5.5 lbs. (2.5 kg.)

MODEL NO.	PRICE CODE NO.	MOTOR VOLTAGE
ODP450-115	52-8008	115V/1/50-60
ODP450-240	52-8009	230-240V/1/50-60

Warning: Not suitable for pumping flammable or combustible liquids

ODP-S



ODP-S OPEN DRIP-PROOF MOTOR w/speed control

1.1 HP (825 watts). Drip-proof motor in rugged glass reinforced plastic housing. Speed control knob allows for efficient, controlled liquid dispensing. ON/OFF switch conveniently located for single hand, thumb control. Resettable thermal overload protected, double insulated motor. Cartridge brush design extends life and greatly reduces replacement service time. Includes 16 ft. cord w/molded plug.

Weight: 8.8 lbs. (4 kg.)

MOTOR MODEL NO.	PRICE CODE NO.	MOTOR VOLTAGE
ODP-S-115	52-8000	115V/1/50-60
ODP-S-240	52-8001	230-240V/1/50-60

Warning: Not suitable for pumping flammable or combustible liquids

ENC-S



ENC-S SEVERE DUTY TOTALLY ENCLOSED MOTOR w/speed control

1.1 HP (825 watts). Totally enclosed motor in anodized aluminum housing for extra protection. Speed control knob allows for efficient, controlled liquid dispensing. ON/OFF switch conveniently located for single hand, thumb control. Resettable thermal overload protected, double insulated motor. Cartridge brush design extends life and greatly reduces replacement service time. Includes 16 ft. cord w/molded plug.

Weight: 12 lbs. (6 kg.)

MODEL NO.	PRICE CODE NO.	MOTOR VOLTAGE
ENC-S-115	52-3000	115V/1/50-60
ENC-S-240	52-3001	220-240V/1/50-60

Warning: Not suitable for pumping flammable or combustible liquids

EXP-UL



EXP-UL EXPLOSION-PROOF MOTOR

.83 HP (620 watts)**. Explosion-proof motor in aluminum housing. C.S.A. and U.L. listed Class I, Groups C and D. Thermal overload protected, automatic reset. Includes 16 ft. cord, no plug.

Weight: 20 lbs. (9.5 kg.)

MODEL NO.	PRICE CODE NO.	MOTOR VOLTAGE
EXC-UL-115	55-0744	115V/1/50-60
EX5-240*	55-7167	220-240V/1/50

*Protection class (PTB): EE_x de 11C T6

** 620 watt input / 430 watt output

May be used for pumping flammable or combustible liquids

AIR (F)



AIR (F) AIR DRIVEN MOTOR

.73 HP (550 watts), 28 cu. ft./min. @ 90 PSI, 10,000 RPM. Aluminum motor housing is plastisol coated to prevent sparking. Includes muffler, filter, and trigger valve for flow control. Air line filter, PSI regulator and automatic oiler recommended.

Weight: 3.5 lbs. (1.6 kg.)

MODEL NO.	PRICE CODE NO.
AIR (F)	52-0100

Warning: Not suitable for pumping flammable or combustible liquids

WARNING: Pumping of flammables or combustible liquids can generate a static electric discharge, causing fire or explosion resulting in injury or death. Read and understand operating instructions before starting this unit. Follow all federal, state and local safety codes including NFPA 30 - NFPA77. Prior to connecting to air supply, install bond and ground wires and check continuity of each wire. A meter reading of one ohm or less is required for safe liquid transfer. Use only metallic drum, receiving vessel and metallic pump when pumping flammables. Air motors are not recognized under any current Underwriter's Laboratory listing program. Consult a qualified engineer for suitability for use in a hazardous area or on flammables.





Technical Data

Design: Progressive Cavity / Positive Displacement
Max. Viscosity: 100,000cps (mPAS)
Discharge Port: 1.5" / 38mm hose barb, optional 1.25" / 32mm
Wetted Material: Tube & Rotor Assembly: 316 Stainless Steel
 Stator Material: See below
Mechanical Seal: SiC/Viton/SiC
Motor Drives: Pneumatic or electric; B phase / 50-60 Hz
 See page 4 for motor selection.
Fittings: Large Type Acme Thread design enables quick disassembly for cleaning and maintenance.



DD 700 Industrial Pump Series

- Easy Maintenance
- Threaded Components
- Interchangeable Motors Drives
- Continuous Flow
- Low Shearing Properties

MODEL NUMBER	PRICE CODE NO.	FLOW RATE**	MAX PRESSURE	PUMP LENGTH
DD700-71-27-* DD700-71-39-* DD700-71-47-*	52-7710* 52-7713* 52-7716*	7 GPM	87 PSI	27" 39" 47"
DD700-72-27-* DD700-72-39-* DD700-72-47-*	52-7711* 52-7714* 52-7717*	7 GPM	174 PSI	33" 45" 53"
DD700-181-27-* DD700-181-39-* DD700-181-47-*	52-7712* 52-7715* 52-7718*	17 GPM	87 PSI	27" 39" 47"

* Add to Model No. and Price Code No.

** Based on water

B for Buna-N
T for PTFE
V for Viton



DD 800 Sanitary Series



- Hygienic Design
- Easy to Clean & Maintain
- Gentle Product Treatment
- Continuous Flow

MODEL NUMBER	PRICE CODE NO.	FLOW RATE**	MAX PRESSURE	PUMP LENGTH
DD800-71-27-* DD800-71-39-* DD800-71-47-*	52-7810* 52-7813* 52-7816*	7 GPM	87 PSI	27" 39" 47"
DD800-72-27-* DD800-72-39-* DD800-72-47-*	52-7811* 52-7814* 52-7817*	7 GPM	174 PSI	33" 45" 53"
DD800-181-27-* DD800-181-39-* DD800-181-47-*	52-7812* 52-7815* 52-7818*	17 GPM	87 PSI	27" 39" 47"

* Add to Model No. and Price Code No.

** Based on water

FG for good grade Buna
T for PTFE



Warning: When pumping flammable or combustible liquids pump tube must be used in conjunction with an explosion proof motor



DD700 & DD800 PUMP MOTORS

P-411A

Industrial Electric Motor



Industrial Electric Motors 230-380-415-460v/3/50-60Hz

MODEL	PRICE CODE NO.	HP	KW	RPM	ENCLOSURE	SHIPPING WT. LBS (Kg)
DD-500	52-8010	0.75	,55	750-900	TEFC (IP55)	40 (18)
DD-510	52-8011	1	,75	750-900	TEFC (IP55)	52 (24)
DD-520	52-8012	1.5	1,1	750-900	TEFC (IP55)	58 (25)

Sanitary Electric Motor



Sanitary Electric Motors 230-380-415-460v/3/50-60Hz

MODEL	PRICE CODE NO.	HP	KW	RPM	ENCLOSURE (WASHDOWN)	SHIPPING WT. LBS (Kg)
DD-502	52-8020	0.75	,55	750-900	TEFC (IP55)	40 (18)
DD-512	52-8021	1	,75	750-900	TEFC (IP55)	52 (24)
DD-522	52-8022	1.5	1,1	750-900	TEFC (IP55)	58 (25)

Industrial Pneumatic Motor



Industrial Pneumatic Motors

MODEL	PRICE CODE NO.	HP	KW	RPM	AIR CONSUMPTION	SHIPPING WT. LBS (Kg)
DD-A4	52-8030	2	1,5	300-900	80 CFM @ 100 psi 37 L/Sec @ 7 Bar	12 (5)
DD-A6	52-8031	4	3,0	300-900	130 CFM @ 100 psi 65 L/Sec @ 7 Bar	24 (11)
DD-A8	52-8032	5	3,7	300-900	170 CFM @ 100 psi 80 L/Sec @ 7 Bar	26 (12)

Sanitary Pneumatic Motor



Sanitary Pneumatic Motors

MODEL	PRICE CODE NO.	HP	KW	RPM	AIR CONSUMPTION	SHIPPING WT. LBS (Kg)
DD-A4FP	52-8040	2	1,5	300-900	80 CFM @ 100 psi 37 L/Sec @ 7 Bar	12 (5)
DD-A6FP	52-8041	4	3,0	300-900	130 CFM @ 100 psi 65 L/Sec @ 7 Bar	24 (11)
DD-A8FP	52-8042	5	3,7	300-900	170 CFM @ 100 psi 80 L/Sec @ 7 Bar	26 (12)

NOTE: Optimal pneumatic motor speed is 300-900 RPM



750 RPM 50 Hz Operation

900 RPM 60 Hz Operation & Pneumatic Motors

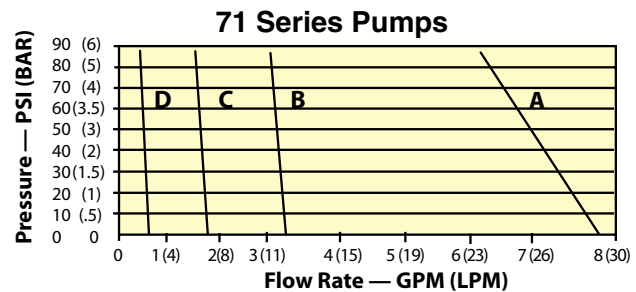
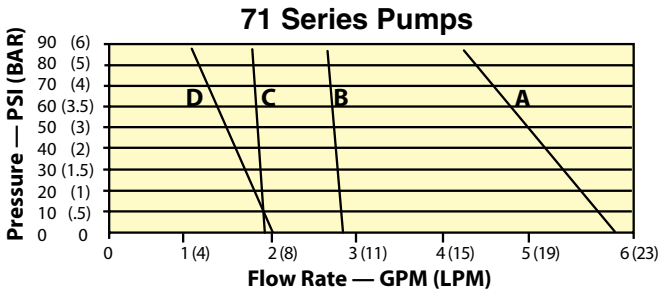

CURVE	VISCOSITY (cps)	HP	KW
A	1+	.5	,37
B	10,000+	1	,75
C	20,000+	1	1,2
D	30,000+	1.5	1,2

CURVE	VISCOSITY (cps)	HP	KW
A	1+	.5	,37
B	10,000+	1	,75
C	20,000+	1	1,2
D	30,000+	1.5	1,2

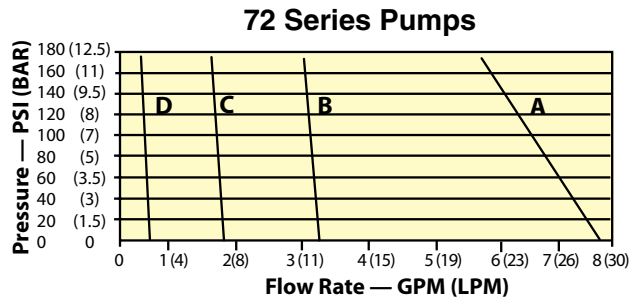
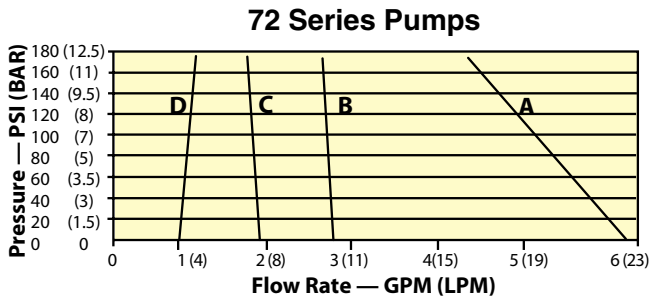

CURVE	VISCOSITY (cps)	HP	KW
A	1+	.5	,37
B	10,000+	1	,75
C	20,000+	1	1,2
D	30,000+	1.5	1,2

CURVE	VISCOSITY (cps)	HP	KW
A	1+	.5	,37
B	10,000+	1	,75
C	20,000+	1	1,2
D	30,000+	1.5	1,2

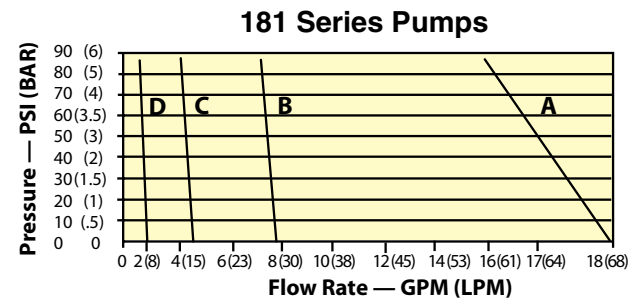
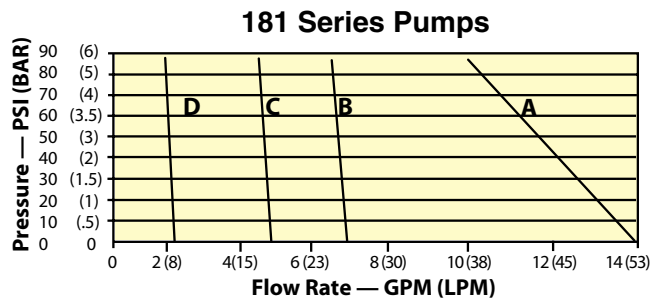

CURVE	VISCOSITY (cps)	HP	KW
A	1+	.5	,37
B	10,000+	1	,75
C	20,000+	1	1,2
D	30,000+	1.5	1,2

CURVE	VISCOSITY (cps)	HP	KW
A	1+	.5	,37
B	10,000+	1	,75
C	20,000+	1	1,2
D	30,000+	1.5	1,2

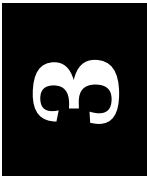



HOSE & CLAMPS



Price Code

NYLON REINFORCED HOSE-CLEAR

1 1/2" I.D. - per foC

22-0434

WIRE REINFORCED HOSE

1 1/2" I.D. - per foC

22-0528

HIGH PRESSURE TRANSFER HOSE

Tube: Black, oil resistant synthetic rubber. (Nitrile). Reinforcement: One braid of high tensile steel wire. Cover: Black, oil and abrasion resistant synthetic rubber. Max. working pressure 725 psi. Max. temp. 180° F

1 1/2" I.D. - per foC

52-9039

PLICORD® GRAY FOOD TRANSFER HOSE

Construction: White Chemivic® synthetic rubber (FDA/USDA, 3A Sanitary Standard 18-03 complaint). Cover: Spiral-plyed synthetic fabric with Galvanized Wire helix. Max. working pressure 150 psi. Max. temp. 180°F

1 1/2" I.D. - per foC

52-9037

VINTNER™ FOOD TRANSFER HOSE (High Pressure)

For handling in-plant and/or tank truck transfer of wine, beer, potable water and other nonoily, liquid foodstuffs. Construction: White Chlorobutyle (FDA/USDA, 3A Sanitary Standard 18-03 complaint). Cover: Grey Versigard® synthetic rubber. Max. working pressure 250 psi. Max. temp. 220°F

1 1/2" I.D. - per foot.....

52-9036

DISCHARGE HOSE CLAMP

Malleable iron two bolt clamp. Gripping ridges, reinforced lugs.
Hose size from 1-48/64" to 2-3/64" (44.50 mm to 27 mm).....

52-9038

PUMP HANGER

For DD direct drive pumps constructed of 304SS tubing.

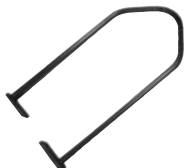

Price Code No.
52-0743

AIR FILTER REGULATOR/LUBRICATOR

To protect all air driven motors, with polycarbonate bowl & pressure gauge (200 psi), 3/8" NPT.

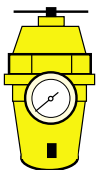

Price Code No.
55-1142



SERIES 'HP' HAND DISPENSING PUMP

65

P-404AB

***For point-of-use dispensing / filtering of water and chemicals used for:
PLATING / PHARMACEUTICAL / INDUSTRIAL / PETROLEUM PRODUCTS
and other stringent applications***



**PREVENT PRODUCT CONTAMINATION.
IMPROVE PRODUCT QUALITY.**

**Optional filter capsule
and discharge spout**

A tough, quality engineered pump

- **QUALITY ENGINEERED THERMOPLASTIC CONSTRUCTION**
- **CONTROLLED DISCHARGE RATE**
The pump discharges approximately one (1) quart on every complete forward and backward cycle.
- **SUCTION LIFT:** Tested for 15 ft. minimum
- **DISCHARGE HEAD:** Up to 25 ft.
- **VISCOSITIES UP TO 2000 SSU**
- **TWO POSITION PUMP HANDLE**
Handle can be mounted above the pump or below.
- **TAMPER PROOF HANDLE**
Can be padlocked to protect against unauthorized use.
- **SELF-LUBRICATING PTFE PISTON RING**
Operates wet or dry for long life

Designed for the transfer or dispensing of concentrates, additives or other liquids which are purchased in bulk but are used in small quantities. This low cost pump delivers one pint per stroke or one quart with the forward and back push/pull of the handle. The variety of materials of construction enables the user to select those which are specifically required for his individual needs according to chemical

resistance charts. The use of this pump eliminates having to pour from one container to another and avoids costly and hazardous spilling and splashing.

***See following page for specifications
and ordering information.***

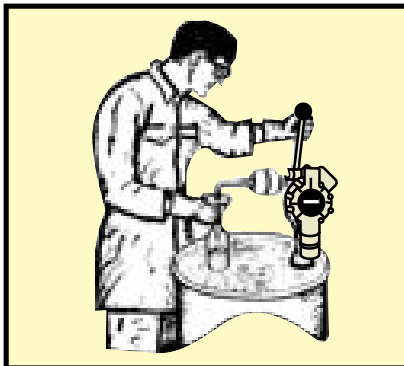

**Optional point of use filter
for filtering/transfer of
pharmaceutical liquids.**

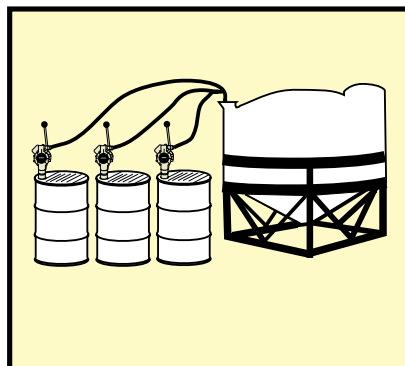

**Liquid transfer
for batch mixing.**

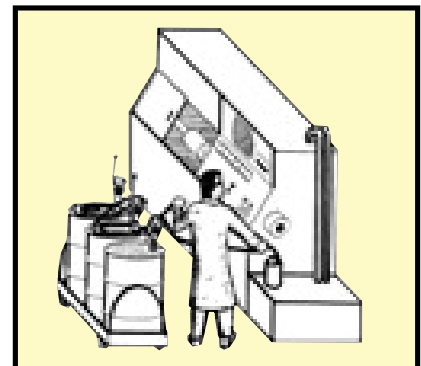

**Low cost permits use of
multiple pumps to avoid
cross-contamination.**

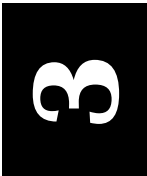



ELIMINATES "DUMPING" & SPILLING OF SOLUTIONS

The HAND DISPENSING PUMP is a double acting piston type which will handle a wide range of solutions. The pump body, valves, valve seats and piston are all made of chemically resistant, performance engineered plastics, especially compounded to give the pump strength and rigidity. All internal metal parts in contact with the liquid are made of 316 stainless steel. The "O"-ring and gasket materials are cork-nitrile, Viton or EPDM (ethylene propylene). 1" NPT suction, 3/4" NPT discharge.



TO ORDER, use Price Code Number
Select pump from chart below and add discharge hose and suction tube to complete assembly

PUMP

MODEL	MATERIALS OF CONSTRUCTION	"O"-RING	GASKET	PRICE CODE NO.
HPV HPN HPE	POLYESTER (glass reinforced) - housing, cover plate, piston, valves and bung adapter	VITON® VITON EPDM	VITON CORK-NITRILE EPDM	59-0001 59-0002 59-0003
HRV HRN HRE	RYTON® (glass reinforced) - housing, cover plate, ECTFE piston, valves and bung adapter	VITON VITON EPDM	VITON CORK-NITRILE EPDM	59-0004 59-0005 59-0006
HHV HHE	ECTFE (Halar®) - housing, cover plate, piston, valves and bung adapter	VITON EPDM	VITON EPDM	59-0007 59-0008

All models have 316 stainless steel piston rod, fasteners and suction screen in contact with liquid. All pumps include a 2" NPT bung adapter.

HOSES & SUCTION TUBE

MODEL	DESCRIPTION	PRICE CODE NO.
DISCHARGE HOSES (Add to Model No. and Price Code No.)		
-1	8' EPDM, w/polyester elbow & nozzle	-1
-2	8' Nitrile (Buna-N), w/polyester elbow & nozzle	-2
-3	8' PVC black vinyl, w/polyester elbow & nozzle	-3
-4	8' Cross linked polyethylene, w/polyester elbow & nozzle	-4
-5	8' Cross linked polyethylene, w/ECTFE elbow & nozzle	-5
-6	8' EPDM, w/ECTFE elbow & nozzle	-6
-7	8' Nitrile (Buna-N), w/ECTFE elbow & nozzle	-7
-8	8' PVC, w/ECTFE elbow & nozzle	-8
SUCTION TUBE (Add to Model No. and Price Code No.)		
-A	2 pc. 1" polyester, 34" long w/polyester coupling & PTFE tape	-A
-B	2 pc. 1" PTFE, 34" long w/ECTFE coupling & PTFE tape	-B
-C	2 pc. 1" UHMW polyethylene#, 34" long w/ECTFE coupling	-C
-E	1 pc. 3/4" PVC flexible, 35" long (prevents tearing of drum liners)	-E

OPTIONAL EQUIPMENT

MODEL	DESCRIPTION	PRICE CODE NO.	
DISCHARGE SPOUT (Add to Model No. and Price Code No.)			
-M	Polyester	-M	
-N	ECTFE	-N	
BUTTRESS-BUNG ADAPTER (2" buttress x 2" NPT) (Add to Model No. & Price Code No.)			
-R	Polypropylene/polyester assembly for HP pump	-R	
-S	Polypropylene/ECTFE assembly for HR pump	-S	
-T	Polypropylene/ECTFE assembly for HH pump	-T	
FILTER CAPSULE-PAC			
FPC-1.0	Polypropylene filter capsule with pleated 1.3 ft. ² polypropylene media, ECTFE pump adapter, ECTFE discharge spout.	1.0 Nominal	59-0011
FPC-0.2		0.2 Nominal	59-0013
FC-1.0	Replacement filter capsule	1.0 Nominal	59-0012
FC-0.2		0.2 Nominal	59-0014

WALL BRACKET 55-7149
 TYPICAL MODEL: HPN-2AM & PRICE CODE NO.: 59-0002-2AM
 Registered trademarks: Teflon, Viton- DuPont Dow Elastomers;

#Ultra High Molecular Weight polyethylene

Ryton- Phillips Chemical; Halar - Ausimont

SAFETY PRECAUTIONS

Plastic pumps are not designed nor intended to be used for transferring flammable or explosive liquids. Only metallic pumps which can be grounded and bonded should be used for this purpose. Refer to a chemical resistance data chart for compatibility of materials with liquids to be pumped. Always wear protective safety clothing such as gloves, apron and goggles.



For dispensing of small quantities.

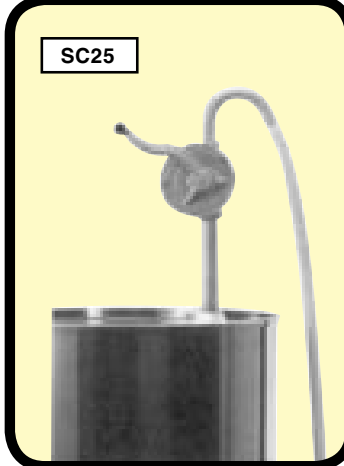
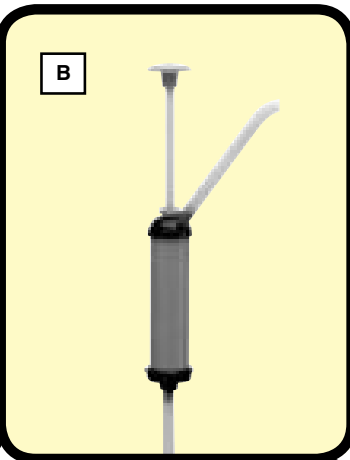
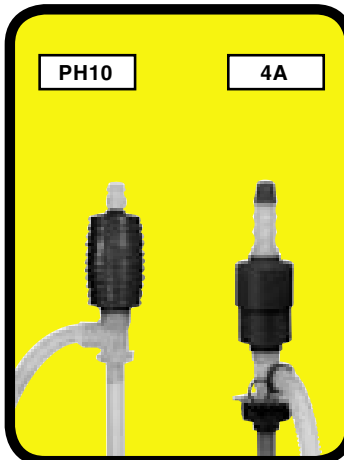

PROTECTIVE APPAREL MUST BE WORN.

MODEL	PRICE CODE NO.
-------	----------------

PH10	56-0000A
------	----------

PLASTIC SYPHON PUMP

All polyethylene construction. Hand operated bellows. Fits 5-gal. cans, bottles or drums. Ideal for mildly corrosive fluids at ambient temperatures. Top vent cap is syphon breaker. 16" long tube, 21" long hose.

4A	56-0011C
----	----------

PLASTIC SYPHON PUMP

All polyethylene. Hand operated bellows and flexible discharge tube will syphon to a lower or pump to a higher level. For dispensing mild acids, caustics, light oils, waxes and disinfectants at ambient temperatures. Top vent cap is syphon breaker, 2" IPS threaded male adapter. 33" long tube, 46" long hose. For 15, 30 and 55 gal. drums. 5 GPM. Wt. 1 lb.

B	56-0003
---	---------

PLASTIC PISTON PUMP

Constructed of polyethylene and polypropylene. Threads onto 2" and 3/4" NPT drum opening. With adjustable suction tube. For 15, 30 and 55 gal. drums.

ROTARY METAL PUMPS

Effortless syphon flow after priming with several turns. For 15, 30 or 55 gal. drums. Ideal for detergents and light oils. Pumps 6 GPM at 60 turns per min. 2" IPS threaded male adapter. Features Buna N gaskets.

Syphons 4 GPM after priming; Pumps 6 GPM @ 60 RPM. Cast iron. Wt. 14 lbs., 52"

SC25	56-0005A
------	----------

Pumps 15 GPM @ 60 RPM. Aluminum. Wt. 14-1/2 lbs., 53"

LP32	56-0022
------	---------

METAL PISTON PUMPS

Fits 15, 30 and 55 gal. containers. Includes 2" IPS threaded male adapter. Pumps 8 oz. on each upstroke. 316 stainless steel and PTFE for alkalies, mild acids.

Chrome plated steel with polyethylene for non-corrosives, soaps, disinfectants.

316SS	56-0175
-------	---------

146C	56-0010
------	---------

OPTIONAL

GROUNDING AND BONDING CABLES

For use with metal pumps and containers to prevent static discharge.

When pumping flammable or combustible liquids from one container to another, both containers must be effectively bonded and grounded to prevent discharge of sparks of static electricity which could cause explosion and bodily harm.

BONDING CABLE

10 ft. long, spring clamp at each end.

PRICE CODE NUMBER

55-0245

GROUNDING CABLE

6 ft. long, spring clamp one end, spade lug one end.

55-0246

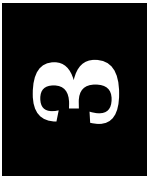



DRUM PUMP CHEMICAL RESISTANCE GUIDE

The information contained in this Drum Pump Chemical Resistance Guide is to be used only as a general guide for proper drum pump tube selection. No warranty is implied nor is any guarantee provided. When compatibility data are inconclusive, field testing is recommended. An asterisk indicates the material is flammable and may only be handled with a stainless steel pump tube and appropriate drive motor which are properly grounded and bonded according to Operating Instructions. Always consult with a safety engineer for proper drive motor selection when pumping flammables. All test data listed is at room temperature (72°F, 22°C) unless otherwise stated.



<p>R = Recommended M = Minor to moderate, should be field tested X = Not recommended — = No data * = Flammable or explosive</p>	 <p>Use only explosion-proof motors on flammable liquids. Only metallic pumps should be used for transferring flammable or explosive liquids. All pumps and containers must be properly grounded and bonded to prevent static discharge and sparking, which could cause electric shock, fire or explosion. A ground wire should be used on any explosion-proof motor as well as the container when transferring explosive material. Always consult with a Safety Engineer for proper pump / motor selection.</p>
--	--

	CPVC/PVDF - MAX. 175°F (80°C) STAINLESS STEEL 316 - MAX. 175°F (80°C) PVDF (KYNAR®) - MAX. 175°F (80°C) POLYPROPYLENE - MAX. 130°F (54°C)					CPVC/PVDF - MAX. 175°F (80°C) STAINLESS STEEL 316 - MAX. 175°F (80°C) PVDF (KYNAR®) - MAX. 175°F (80°C) POLYPROPYLENE - MAX. 130°F (54°C)			
* Acetaldehyde	X	X	R	X	Ammonium persulfate	R	R	R	R
Acetamide (PVDF, R to 75°F/24°C)	—	R	R	—	Ammonium phosphate, dibasic	R	R	R	R
* Acetate solvents	X	X	R	X	Ammonium phosphate, monobasic	R	R	R	R
Acetic acid (10% -80%)	R	R	M	R	Ammonium phosphate, tribasic	R	R	R	R
Acetic acid (80%)	—	R	M	X	Ammonium sulfate	R	R	R	R
Acetic acid, glacial (PVDF, R to 120°F/49°C) (PP, R to 100°F/38°C)	R	R	M	X	Ammonium sulfide (PVDF & CPVC / PVDF, R to 125°F/52°C)	—	R	—	R
Acetic anhydride	X	X	R	X	Ammonium thiocyanate	—	R	—	R
* Acetone	X	X	R	X	Ammonium thiosulfate	—	R	R	R
* Acetyl chloride	X	X	M	X	* Amyl acetate	X	X	R	X
* Acetylene	X	X	R	X	* Amyl chloride	X	X	R	X
* Alcohols	X	X	R	X	Aniline (PVDF, R to 75°F/24°C)	M	R	R	X
Aluminum chloride	R	R	X	R	Aniline dyes	—	—	M	—
Aluminum fluoride	R	R	X	R	Aniline hydrochloride (PVDF, R to 75°F/24°C)	—	R	X	X
Aluminum hydroxide	R	R	R	R	Anisole	—	—	R	—
Aluminum nitrate	R	R	R	R	Aqua regia (80%) (PVDF, R to 75°F/24°C)	X	R	X	X
Aluminum potassium sulfate	R	R	R	R	Arsenic acid	R	R	R	R
Aluminum sulfate	R	R	R	R	Barium carbonate	R	R	R	R
Amines	—	—	R	X	Barium chloride	R	R	M	R
* Ammonia, aqua (10%)	X	X	R	X	Barium hydroxide	R	R	R	R
* Ammonia, aqueous	X	X	R	X	* Barium nitrate	X	X	R	X
* Ammonia, (concentrated)	X	X	R	X	Barium sulfate	R	R	R	R
Ammonium bifluoride (PP, R to 70°F/21°C)	R	R	R	R	Barium sulfide	R	R	R	R
Ammonium carbonate	R	R	R	R	Benzaldehyde (PVDF, R to 75°F/24°C)	X	R	R	X
Ammonium chloride	R	R	M	R	Benzene, benzol	X	X	R	X
Ammonium fluoride (10%)	—	R	—	R	Benzene sulfonic acid (PVDF, R to 75°F/24°C)	—	R	M	X
Ammonium fluoride (25%)	R	R	—	R	Benzoic acid	M	R	R	R
Ammonium hydroxide	R	R	R	X	Bismuth carbonate	R	R	—	R
Ammonium nitrate	R	R	R	R	Black liquors	R	R	—	—
Ammonium nitrite (PP, R to 70°F/21°C)	R	—	—	—	Boric acid	R	R	R	R
Ammonium oxalate	R	—	R	—	Brine acid	—	R	—	—
					Potassium hydroxide	R	R	R	R



DRUM PUMP Chemical Resistance Guide (cont'd.)

R = Recommended
M = Minor to moderate, should be field tested
X = Not recommended
— = No data
***** = Flammable or explosive

 Use only explosion-proof motors on flammable liquids. Only metallic pumps should be used for transferring flammable or explosive liquids. All pumps and containers must be properly grounded and bonded to prevent static discharge and sparking, which could cause electric shock, fire or explosion. A ground wire should be used on any explosion-proof motor as well as the container when transferring explosive material. Always consult with a Safety Engineer for proper pump / motor selection.

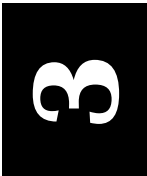

	CPVC / PVDF - MAX. 175°F (80°C)	STAINLESS STEEL 316 - MAX. 175°F (80°C)	PVDF (KYNAR®) - MAX. 175°F (80°C)	POLYPROPYLENE - MAX. 130°F (54°C)		CPVC / PVDF - MAX. 175°F (80°C)	STAINLESS STEEL 316 - MAX. 175°F (80°C)	PVDF (KYNAR®) - MAX. 175°F (80°C)	POLYPROPYLENE - MAX. 130°F (54°C)
Bromic acid	R	R	—	R	Cresylic acid (PVDF, R to 150°F/66°C)	—	R	R	M
Bromine liquid (PVDF, R to 150°F/66°C)	—	R	X	X	* Cyclohexane	X	X	R	X
Bromine water	—	R	M	X	* Cyclohexanol	X	X	M	X
* Butane	X	X	R	X	* Cyclohexanone	X	X	M	X
* Butyl acetate	X	X	M	X	Diacetone alcohol	X	X	R	X
Butyl phenol	—	—	—	—	* Dichloroethylene	X	X	X	X
* Butylene	X	X	R	X	Diesel fuels	X	R	R	X
Butyric acid	R	R	R	X	* Diethyl ether	X	X	M	X
Calcium bisulfide	R	R	M	R	* Diisobutylene	X	X	M	X
Calcium bisulfite	R	R	M	R	Dimethyl formamide	—	X	R	X
Calcium chlorate	R	R	R	R	Diocyl phthalate	—	—	R	—
Calcium chloride	R	R	M	R	Dyes	—	—	R	—
Calcium hydroxide	R	R	R	R	* Epichlorohydrine	X	X	R	X
Calcium hypochlorite (PVDF & CPVC / PVDF, R to 70°F/21°C)	R	R	R	R	* Ethanolamine	X	X	R	X
Calcium nitrate	R	R	M	R	* Ether	X	X	R	X
Calcium sulfate	R	R	R	R	* Ethyl acetate	X	X	R	X
Calcium sulfite	R	—	M	—	* Ethyl chloride	X	X	R	X
* Carbon disulfide	X	X	R	X	* Ethyl ether	X	X	R	X
Carbonic acid	R	R	R	R	* Ethylene chloride	X	X	R	X
Carbon tetrachloride	X	R	R	X	* Ethylene dichloride	X	X	R	X
Cellosolve®	R	R	M	X	Ethylene glycol	R	R	R	R
* Cetyl alcohol	X	X	R	X	* Ethylene oxide	X	X	—	X
Chlorine liquid	X	R	X	X	Fatty acids	M	M	R	M
Chloroacetic acid	X	X	X	X	Ferric chloride	R	R	M	R
* Chlorobenzene	X	X	R	X	Ferric nitrate	R	R	R	R
Chlorobenzyl chloride (PVDF, R to 125°F/52°C)	—	R	—	X	Ferric sulfate	R	R	X	R
Chloroform (PVDF, R to 125°F/52°C)	X	R	R	X	Ferrous chloride	R	R	M	R
Chlorosulfonic acid (100%)	X	X	X	X	Ferrous sulfate	R	R	M	R
Chromic/sulfuric acid	X	X	X	X	Fluoboric acid (CPVC / PVDF, R to 140°F/60°C)	R	R	M	R
Chromic acid (10%) (PVDF & CPVC / PVDF, R to 120°F/49°C)	R	R	R	R	Fluosilicic acid	R	M	—	M
Chromic acid (50%) (PVDF, R to 120°F/49°C) (CPVC / PVDF, R to 70°F/21°C)	R	R	M	R	Formaldehyde (PVDF, R to 120°F/49°C)	R	R	R	X
Citric acid	R	R	R	R	Formic acid	R	R	R	X
Citric oils	R	—	R	—	Furfural	X	M	R	X
Copper chloride	R	R	X	R	Gallic acid (PVDF & CPVC / PVDF, R to 75°F/24°C)	M	R	M	R
Copper cyanide	R	R	R	R	Gelatin	X	R	R	R
Copper nitrate	R	R	R	R	Glue P. V. A.	M	R	R	R
* Copper sulfate	R	R	R	R	Glycerin	R	R	R	R
					Glycolic acid (PP, R to 70°F/21°C) (PVDF & CPVC / PVDF, R to 75°F/24°C)	R	R	—	R
					Glycols	—	R	M	R



DRUM PUMP Chemical Resistance Guide (cont'd.)

- R** = Recommended
- M** = Minor to moderate, should be field tested
- X** = Not recommended
- = No data
- *** = Flammable or explosive



Use only explosion-proof motors on flammable liquids. Only metallic pumps should be used for transferring flammable or explosive liquids. All pumps and containers must be properly grounded and bonded to prevent static discharge and sparking, which could cause electric shock, fire or explosion. A ground wire should be used on any explosion-proof motor as well as the container when transferring explosive material. Always consult with a Safety Engineer for proper pump / motor selection.

3

	CPVC / PVDF - MAX 175°F (80°C)				STAINLESS STEEL 316 - MAX 175°F (80°C)				PVDF (KYNAR®) - MAX 175°F (80°C)				POLYPROPYLENE - MAX 130°F (54°C)			
* Heptane	X	X	R	X												
* Hexane	X	X	R	X												
Hydrobromic acid	M	R	X	R												
Hydrochloric acid (20%)	R	R	X	R												
Hydrochloric acid (37%) (cold)	R	R	X	R												
Hydrochloric acid (37%) (hot)	—	R	X	R												
Hydrofluoric acid (20%)	R	R	X	X												
Hydrofluoric acid (50%)	X	R	X	X												
Hydrofluoric acid (75%)	X	R	X	X												
Hydrofluoric acid (conc.) (cold)	—	R	—	X												
Hydrofluosilicic acid (20%)	R	R	X	R												
Hydrogen fluoride	R	—	R	—												
* Hydrogen peroxide	X	X	R	X												
* Hydrogen sulfide (cold)	X	X	R	X												
* Hydrogen sulfide (hot)	X	X	R	X												
Hypochlorous acid	—	R	X	R												
Iodine (PVDF, R to 150°F/66°C)	M	R	X	M												
* Isopropyl ether	X	X	R	X												
* Jet fuel (JP3, JP4, JP5)	X	X	R	X												
* Lacquer solvents	X	X	R	X												
Lactic acid (PVDF & CPVC / PVDF, R to 120°F/49°C)	R	R	R	R												
Lead acetate	R	R	M	R												
Lead sulfamate	R	—	—	—												
* Ligroin	X	X	R	X												
Magnesium carbonate	R	R	R	R												
Magnesium chloride	R	R	R	R												
Magnesium hydroxide	R	R	R	R												
Magnesium sulfate	R	R	R	R												
Maleic acid	M	R	R	R												
Mercuric chloride (dilute solution)	R	R	X	R												
Mercuric cyanide	R	R	R	R												
* Methyl acetone	X	X	R	X												
Methyl chloride	X	R	R	X												
* Methyl ethyl ketone	X	X	R	X												
* Methyl isobutyl ketone	X	X	R	X												
Methylene chloride	X	X	R	X												
Milk	R	R	R	R												
* Monoethanolamine	X	X	R	X												
Muriatic acid (20%)	R	R	X	R												
Muriatic acid (37%) (cold)	R	R	X	R												
Muriatic acid (37%) (hot)	—	R	X	R												
* Naptha	X	X	R	X												
* Napthalene	X	X	M	X												
Nickel chloride	R	R	R	R												
Nickel sulfate	R	R	R	R												
Nitric acid (5-10%)	R	R	R	R												
Nitric acid (20%)	R	R	R	R												
Nitric acid, (conc.) (PVDF, R to 120°F/49°C)	X	R	R	X												
Nitric acid, red fuming	—	X	R	X												
Nitrobenzene (PVDF, R to 75°F/24°C)	M	R	M	X												
Oleic acid	R	R	R	X												
Oleum	X	X	R	X												
Oxalic acid (cold) (PVDF, R to 125°F/52°C)	R	R	R	R												
Palmitic acid	M	R	R	R												
Perchloric acid (PVDF, R to 125°F/52°C)	—	R	X	M												
Perchloroethylene	X	R	R	X												
Petrolatum	—	R	R	R												
Phenol (carbolic acid)	R	R	R	R												
Phosphoric acid (20%)	R	R	M	R												
Phosphoric acid (20%-40%)	R	R	R	R												
Phosphoric acid (45%)	R	R	M	R												
Phosphorus, red	—	—	R	—												
Phosphorus, yellow	—	—	R	—												
Photographic solutions	R	—	R	—												
Plating solutions, chrome 40	R	R	R	R												
Plating solutions, copper	R	R	R	R												
Plating solutions, gold	R	—	R	—												
Plating solutions, iron	R	R	R	R												
Plating solutions, lead	R	R	—	R												
Plating solutions, nickel	R	R	—	R												
Plating solutions, silver	R	R	R	R												
Plating solutions, tin	R	R	R	R												
Plating solutions, zinc	R	R	R	R												
Potassium bicarbonate	R	R	M	R												
Potassium bromide	R	R	R	R												
Potassium carbonate	R	R	R	R												
Potassium chlorate	R	R	R	R												
Potassium chloride	R	R	R	R												
Potassium chromate	R	R	M	R												
Potassium dichromate	R	R	R	R												



DRUM PUMP Chemical Resistance Guide (cont'd.)

TP-107C

R = Recommended	 <p>Use only explosion-proof motors on flammable liquids. Only metallic pumps should be used for transferring flammable or explosive liquids.</p> <p>All pumps and containers must be properly grounded and bonded to prevent static discharge and sparking, which could cause electric shock, fire or explosion. A ground wire should be used on any explosion-proof motor as well as the container when transferring explosive material. Always consult with a Safety Engineer for proper pump / motor selection.</p>
M = Minor to moderate, should be field tested	
X = Not recommended	
— = No data	
* = Flammable or explosive	

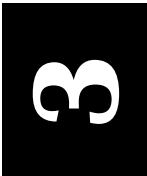

	CPVC / PVDF - MAX. 175°F (80°C) STAINLESS STEEL 316 - MAX. 175°F (80°C) PVDF (KYNAR®) - MAX. 175°F (80°C) POLYPROPYLENE - MAX. 130°F (54°C)					CPVC / PVDF - MAX. 175°F (80°C) STAINLESS STEEL 316 - MAX. 175°F (80°C) PVDF (KYNAR®) - MAX. 175°F (80°C) POLYPROPYLENE - MAX. 130°F (54°C)			
(PVDF & CPVC / PVDF, R to 150°F/66°C)	R	R	R	R	Stannic chloride	R	R	X	R
Potassium nitrate	R	R	R	R	Stearic acid	X	R	R	R
Potassium permanganate	M	R	M	R	Sulfate liquors	R	—	X	R
Potassium sulfate	R	R	M	R	Sulfur	R	R	R	—
Propionic acid (CPVC / PVDF, R to 140°F/60°C)	—	R	R	R	Sulfur chloride (PVDF, R to 75°F/24°C)	X	R	X	R
M Silicone oil	R	R	R	R	Sulfur dioxide	X	R	R	R
Silver nitrate	R	R	R	R	Sulfuric acid (10%)	R	R	M	X
Soap solutions	R	R	R	R	Sulfuric acid (10%-75%)	R	R	M	R
Sodium acetate	X	X	R	R	Sulfuric acid (66° Baumé)	X	R	M	R
Sodium bicarbonate	R	R	R	X	(PVDF & CPVC / PVDF, R to 120°F/49°C)				R
Sodium bisulfate	R	R	R	R	Sulfurous acid	R	R	M	
Sodium bisulfite	R	R	R	R	Tannic acid	R	R	R	R
Sodium borate	—	R	M	R	Tartaric acid	R	R	R	R
Sodium bromide	R	R	R	R	Tetrahydrofuran	X	X	R	R
Sodium carbonate	R	R	R	R	* Tetralin	—	—	R	X
Sodium chlorate (50%)	R	R	R	R	Titanium tetrachloride (PVDF, R to 150°F/66°C)	—	R	M	—
Sodium chloride	R	R	R	R	Toluene (toluol)	X	X	R	X
Sodium cyanide	R	R	R	R	* Transformer oil	R	—	R	X
Sodium hydroxide (20%)	R	R	R	R	Trichloroacetic acid	—	R	X	—
Sodium hydroxide (50%)	R	X	M	R	(PVDF & CPVC/PVDF, R to 75°F/24°C)				R
Sodium hydroxide (80%)	R	X	X	X	1, 1, 1, Trichloroethane	—	—	X	—
Sodium hypochlorite to 20%	X	R	X	X	Trichloroethylene	X	R	R	—
Sodium metaphosphate	X	—	R	R	Tricresylphosphate	—	X	R	X
Sodium nitrate	R	R	R	—	Triethylamine (PVDF, R to 125°F/52°C)	—	R	—	X
Sodium perborate	R	—	X	R	Vinyl chloride	X	X	—	X
Sodium phosphate	R	R	M	—	* Wood oil	X	X	R	X
Sodium silicate	R	R	R	R	* Xylene (xylol)	X	X	R	X
Sodium sulfate	R	R	R	R	* Zinc hydrosulfite	—	R	R	X
Sodium sulfide	R	R	R	R					R
Sodium thiosulfate	R	R	R	R					