

PUMP ANYTHING THAT CAN POUR SAFELY AND RELIABLY

- **Wide selection of materials:**
 - SS - 316 stainless steel
 - AL - Aluminum
 - NSS - Conductive nylon
 - PP - Polypropylene
 - K - PVDF
 - N - Nylon
- **1/4" - 2" sizes —**
flows to 150 U.S. GPM (568 l/m)
- **Patented lube-free air system**
- **Will not stall at slow speeds**
- **Self-priming**
- **Runs dry**

Here is a line of remarkably rugged and durable self-priming, double diaphragm pumps. Lube-free and non-stalling, all models will handle any product that pours, from clear water to highly viscous, abrasive and chemically aggressive materials. Proven to handle suspended solids and abrasives without damage to the product or the pump.

The unique pump design utilizes far fewer parts than other pumps on the market. This results in

longer operating life and easier maintenance at a lower cost.

Since these pumps are driven by compressed air, there is no need for shielded electrical connections or explosion-proof motors. All models can run dry because there are no close fitting or sliding parts in the fluid section. Flow rates can be controlled to produce from zero to maximum flow simply by increasing or decreasing air flow or pressure.

1/4" BOLTED



SPECIFICATIONS

- Capacity:**
Adjustable 0 to 4.3 GPM (16.3 liters/min.)
- Maximum temperature:**
PVDF model 200°F (93°C)
Other models 150°F (66°C)
- Maximum air pressure:**
All models 100 PSI (6.8 bars)
- Dry lift capacity @ 100 PSI (6.8 bars):** 15 ft. (4.5 meters)
- Maximum solids:** 1/16" (1.6 mm)
- Air supply:**
Inlet 1/4" NPT
Outlet 1/4" NPT
- Fluid inlet / discharge:** 1/4" NPT

PLASTIC MODELS:

- PPBN-1/4 PPBTF-1/4 PPBL-1/4 NSSBTF-1/4
- NBTF-1/4 KBTF-1/4 KBL-1/4

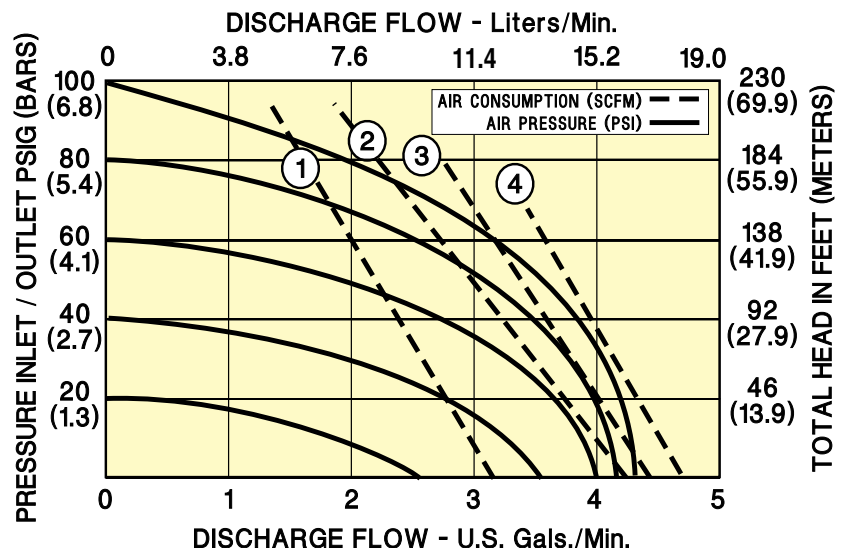

AIR OPERATED DIAPHRAGM PUMP Specifications

1/2" BOLTED

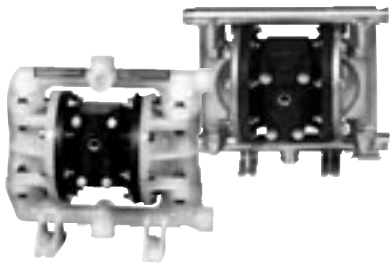

PLASTIC MODELS: PPBN-1/2, PPBTF-1/2, PPBL-1/2, PPBV-1/2, NBTF-1/2, KBTF-1/2, KBL-1/2, KBV-1/2, NSSBTF-1/2
METALLIC MODELS: ALBN-1/2, ALBTF-1/2, ALBL-1/2, SSBTF-1/2, SSBL-1/2, SSBN-1/2

SPECIFICATIONS

Capacity:
Adjustable 0-17 GPM (64.6 liters/min.)

Maximum temperature:
PVDF, AL and SS models 200°F (93°C)
Other models 150°F (66°C)

Minimum air pressure: 20 PSI (1.4 bar)

Maximum air pressure: 120 PSI (8.0 bars)

Dry lift capacity @ 120 PSI (8.0 bars): 10 ft. (3 meters)

Maximum solids: 1/8" (3.2 mm)

Air supply: 1/4" FNPT

Fluid inlet / discharge: 1/2" FNPT
(FBSP available. Specify when ordering.)

- Stock models have a side port. Optional center, top or dual ports must be specified when ordering. Fluid is not separated within the single piece manifold when dual ports are specified.

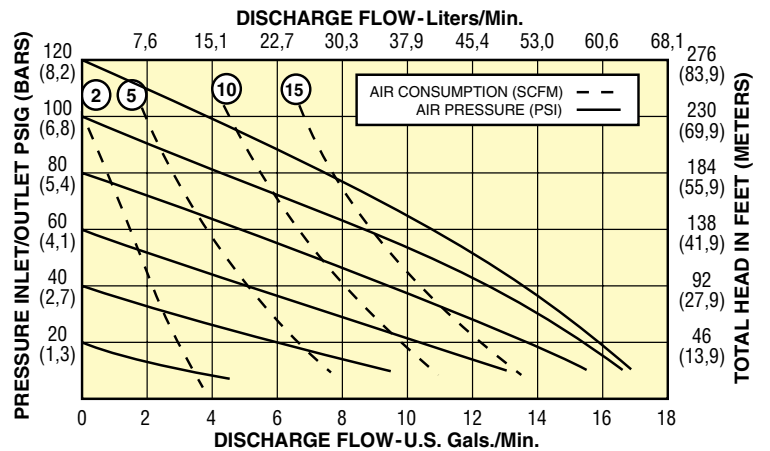

1/2" BAND CLAMP

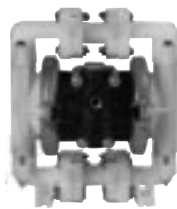

PLASTIC MODELS: PPN-1/2, PPTF-1/2, PPL-1/2, NTF-1/2, KTF-1/2

SPECIFICATIONS

Capacity:
Adjustable 0 - 14 GPM (53.2 liters/min.)

Maximum temperature:
PVDF model 200°F (93°C)
Other models 150°F (66°C)

Minimum air pressure: 20 PSI (1.4 bars)

Maximum air pressure: 100 PSI (6.8 bars)

Dry lift capacity @ 100 PSI (6.8 bars): 10 ft. (3 meters)

Maximum solids: 1/8" (3.2 mm)

Air supply: 1/4" FNPT

Fluid inlet / discharge: 1/2" FNPT

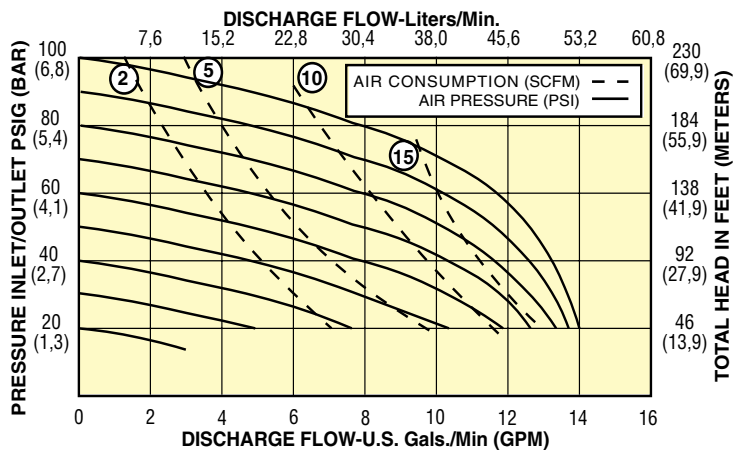

AIR OPERATED DIAPHRAGM PUMP Specifications and ordering information

1"

BOLTED

PLASTIC MODELS: PPBN-1, PPBTF-1, PPBL-1, PPBV-1
KTBF-1, KBL-1, KBV-1

METALLIC MODELS: ALBN-1, ALBTF-1, ALBL-1,
SSBTF-1, SSBL-1, SSBN-1

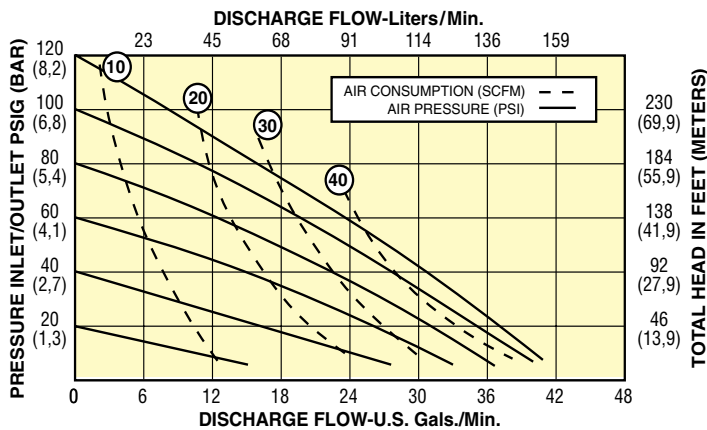
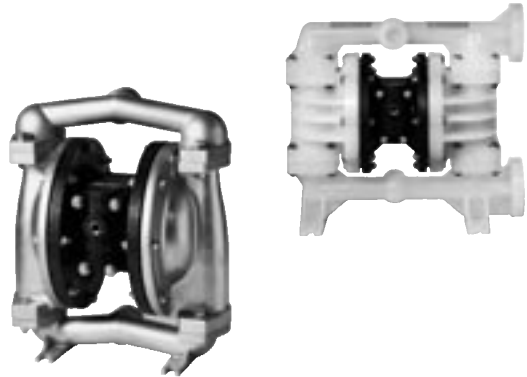

SPECIFICATIONS

- Capacity:**
Adjustable 0 to 41 GPM (156 liters/min.)
- Maximum temperature:**
PVDF, AL and SS models 200°F (93°C)
Other models 150°F (66°C)
- Minimum air pressure:** 20 PSI (1.4 bar)
- Maximum air pressure:** 120 PSI (8.0 bars)
- Dry lift capacity @ 120 PSI (8.0 bars):**
Models w/TFE balls 10 ft. (3 meters)
Other models 15 ft. (4.5 meters)
- Maximum solids:** 1/4" (6.4 mm)
- Air supply:**
Inlet 1/4" FNPT
Outlet 3/8" FNPT
- Fluid inlet / discharge:**
Plastic Models 1" Flange ANSI/DIN compatible
Metallic Models 1" NPT

1"

BAND CLAMP

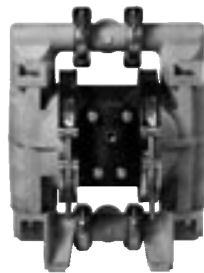

PLASTIC MODELS: PPN-1, PPTF-1, PPL-1,
NTF-1, KTF-1,

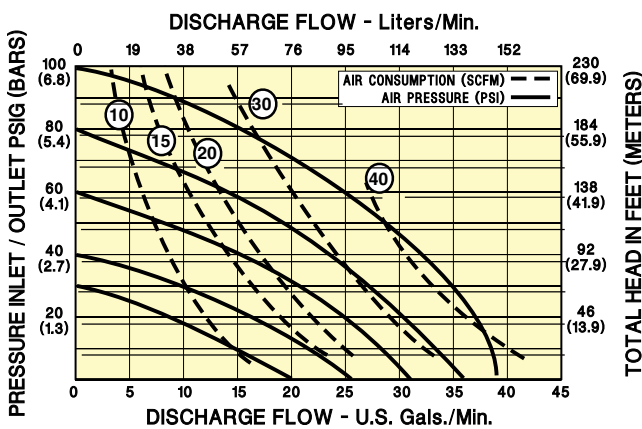

SPECIFICATIONS

- Capacity:**
Adjustable.. 0 to 40 GPM (152 liters/min.)
- Maximum temperature:**
PVDF model 200°F (93°C)
Other models 150°F (66°C)
- Maximum air pressure:**
PVDF model 70 PSI (4.8 bars)
Other models 100 PSI (6.8 bars)
- Dry lift capacity @ 100 PSI (6.8 bars):**
Models w/TFE balls 10 ft. (3 meters)
Other models 15 ft. (4.5 meters)
- Maximum solids:** 1/4" (6.4 mm)
- Air supply:**
Inlet 1/4" FNPT
Outlet 3/4" FNPT
(Air flow control valve on plastic pumps, 1/4" FNPT)
- Fluid inlet / discharge:** 1" FNPT

AIR OPERATED DIAPHRAGM PUMP Specifications

1-1/2" BAND CLAMP

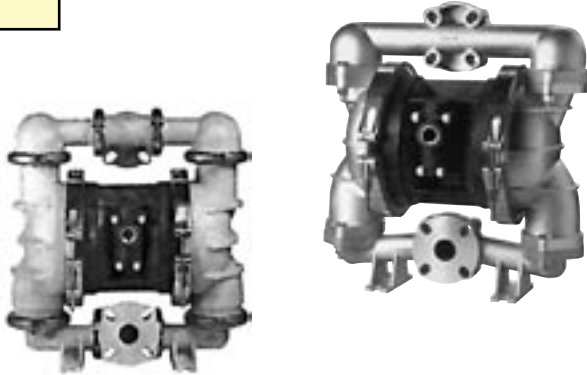

PLASTIC MODELS: PPN-1½, PPTF-1½, PPL-1½, KTF-1½, KL-1½

METALLIC MODELS: ALN-1½, ALTF-1½, ALL-1½, SSTF-1½, SSL-1½, SSN-1½

SPECIFICATIONS

Capacity:
Adjustable 0 to 95 GPM (360 liters/min.)

Maximum temperature:
PVDF, AL & SS models.....200°F (93°C)
Other models.....150°F (66°C)

Minimum air pressure:.....20 PSI (1.2 bars)

Maximum air pressure:
PVDF model.....70 PSI (4.8 bars)
Other models.....100 PSI (6.8 bars)

Dry lift capacity @ 100 PSI (6.8 bars):
.....10 ft. (3 meters)

Maximum solids:1/4" (6.4 mm)

Air supply:
Inlet.....3/4" FNPT
Outlet.....3/4" FNPT
(Air flow control valve on plastic pumps, 3/4" FNPT)

Fluid inlet / discharge:
Plastic pumps1½" flange
Metal pump.....1½" flange (38 mm)

(ANSI & DIN compatible)

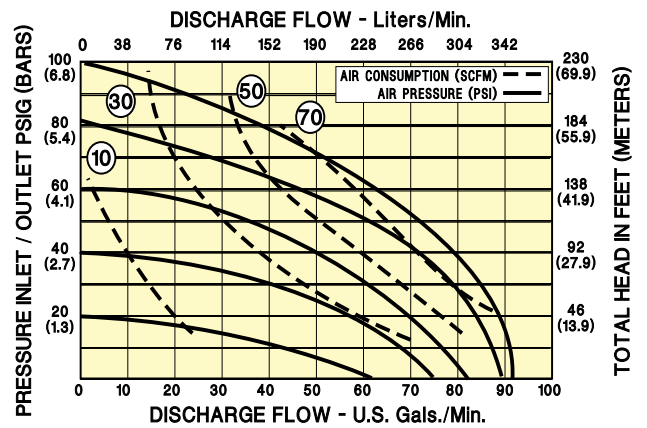

2" BAND CLAMP

PLASTIC MODELS: PPN-2, PPTF-2, PPL-2, NTF-2, KTF-2, KL-2

METALLIC MODELS: ALN-2, ALTF-2, ALL-2, SSTF-2, SSL-2, SSN-2

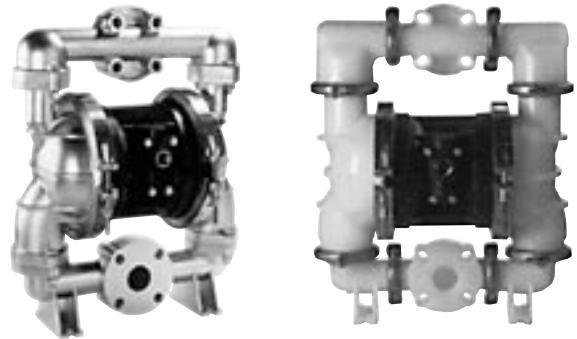

SPECIFICATIONS

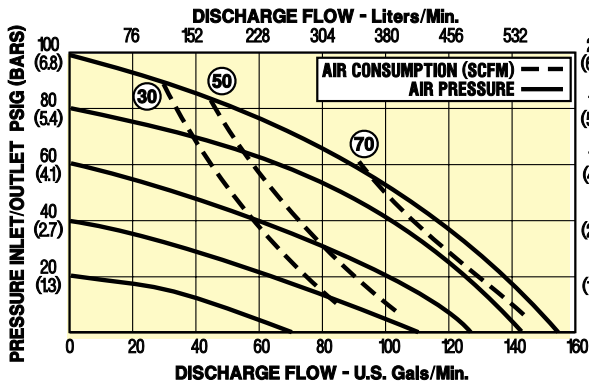

Capacity:
Adjustable..0 to 150 GPM (569 liters/min.)

Maximum temperature:
PVDF, AL & SS models.....200°F (93°C)
Other models.....150°F (66°C)

Minimum air pressure for AL & SS pumps:
.....30 PSI (2.0 bars)

Maximum air pressure:
PVDF model.....70 PSI (4.8 bars)
Other models.....100 PSI (6.8 bars)

Dry lift capacity @ 100 PSI (6.8 bars):
.....10 ft. (3 meters)

Maximum solids:
.....1/4" (6.4 mm)

Air supply:
Inlet3/4" FNPT
Outlet3/4" FNPT
(Air flow control valve on plastic pumps, 3/4" FNPT)

Fluid inlet / discharge:
Plastic pumps.....2" flange
Metal pumps.....2" flange (51 mm)
(ANSI & DIN compatible)

AIR OPERATED DIAPHRAGM PUMP Specifications and ordering information

TO ORDER, Use Price Code No.

BOLTED MODELS

MODEL NUMBER *	MATERIAL OF CONSTRUCTION		PRICE CODE NUMBER		
	WETTED HOUSINGS**	DIAPHRAGM ELASTOMERS/ VALVE SEATS**	1/4"	1/2"	1"
			0-4 GPM (16 l/m)	0-14 GPM (53 l/m)	0-40 GPM (152 l/m)
PPBN-_* PPBTf-_* PPBL-_* PPBV-_*	Polypropylene Polypropylene Polypropylene Polypropylene	Geolast® / Nitrile PTFE Santoprene® / EPDM Viton	55-7244B 55-7245 55-7270 —	55-7287 55-7288 55-7289 55-7290	55-7602 55-7603 55-7604 55-7605
NBTf-_*	Nylon	PTFE	55-7246	55-7291	—
NSSBTf-_*	Conductive Nylon	PTFE	55-7271	55-7292	—
KBTF-_* KBL-_* KBV-_*	PVDF PVDF PVDF	PTFE Santoprene® / EPDM Viton	55-7247 55-7286 —	55-7293 55-7294 55-7295	55-7606 55-7607 55-7608
ALBN-_* ALBTf-_* ALBL-_*	Aluminum Aluminum Aluminum	Geolast® / Nitrile PTFE / nylon Santoprene® / EPDM / PP	— — —	55-7296 55-7297 55-7298	55-7609 55-7610 55-7611
SSBTf-_* SSBL-_* SSBN-_*	Stainless steel Stainless steel Stainless steel	PTFE Santoprene® / EPDM Geolast® / Nitrile	— — —	55-7600 55-7601 55-7299	55-7612 55-7613 55-7614

* Insert pump size to complete Model Number: i.e. PPBN - 1/4
** See Material notes on page 6

BAND CLAMP MODELS

MODEL NUMBER *	MATERIAL OF CONSTRUCTION		PRICE CODE NUMBER			
	WETTED HOUSINGS**	DIAPHRAGM ELASTOMERS/ VALVE SEATS**	1/2"	1"	1 1/2"	2"
			0-14 GPM (53 l/m)	0-40 GPM (152 l/m)	0-95 GPM (360 l/m)	0-150 GPM (569 l/m)
PPN-_* PPTf-_* PPL-_*	Polypropylene Polypropylene Polypropylene	Geolast® / Nitrile PTFE Santoprene® / EPDM	55-7120B 55-7118A 55-7248	55-7144B 55-7145A 55-7249	55-7278 55-7279 55-7280	55-7208B 55-7209 55-7250
NTf-_*	Nylon	PTFE	55-7119A	55-7146A	—	55-7210
KTF-_* KL-_*	PVDF PVDF	PTFE Santoprene® / EPDM	55-7110A —	55-7147A —	55-7281 55-7282	55-7211 55-7285
ALN-_* ALTf-_* ALL-_*	Aluminum Aluminum Aluminum	Geolast® / Nitrile PTFE / nylon Santoprene® / EPDM	— — —	— — —	55-7258 55-7259 55-7260	55-7264 55-7265 55-7266
SSTf-_* SSL-_* SSN-_*	Stainless steel Stainless steel Stainless steel	PTFE Santoprene® / EPDM Geolast® / Nitrile	— — —	— — —	55-7261 55-7262 55-7263	55-7267 55-7268 55-7269

* Insert pump size to complete Model Number: i.e. PPN-1/2
** See Material notes on Page 6

AIR OPERATED DIAPHRAGM PUMP Specifications and ordering information

Material notes:

1. Geolast is a nitrile blend and is a replacement for Buna-N or Neoprene®. Use chemical resistance information for Buna-N.
2. Santoprene is an EPDM blend and is highly resistant to some acids and bases. Use the chemical resistance information for EPDM.
3. Aluminum pumps have polypropylene valve seats, except aluminum w/ TFE models which have nylon valve seats.
4. All pumps built with TFE contain a backup diaphragm of Santoprene.
5. NSSTF pumps are constructed of 316SS filled nylon and include ground / bond lugs.
6. Air system constructed of polypropylene, except nylon and aluminum w/TFE models which have nylon air systems.

General product notes:

1. All pumps are lube-free and non-stalling. A clean, dry compressed air supply is all that is needed.
2. BSP thread models available. Consult Sales Department.
3. Flanges, available on 1½" and 2" sizes only, are slotted for DIN or ANSI compatibility.

SHIPPING WEIGHTS

HOUSING MATERIAL	SHIPPING WEIGHT LBS (kg)						
	¼"	½" BOLTED	½" CLAMP	1" BOLTED	1" CLAMP	1½" CLAMP	2" CLAMP
Polypropylene, Nylon	5 (2.3)	9 (4.1)	8 (3.6)	20 (9.1)	19 (8.6)	52 (24)	54 (25)
Conductive Nylon, PVDF	7 (3.2)	12 (5.4)	11 (4.9)	30 (13.7)	22 (9.9)	66 (30)	68 (31)
Aluminum	—	10 (4.5)	—	23 (10.5)	—	61 (28)	63 (29)
Stainless Steel	—	19 (8.6)	—	45 (20.4)	—	113 (51)	131 (59)

OPTIONAL EQUIPMENT



ACCESSORY KIT for drum transfer applications Turns diaphragm pump into an ideal drum pump. Includes: polypropylene or PVDF suction tube with 2" NPT polypropylene barrel adapter.	PUMP SIZE	PRICE CODE NUMBER		
		PP	PVDF	AL
	1/2"	44-7236	44-7239	44-7628
	1"	44-7237	44-7240	—

AIR PRESSURE REGULATOR	INLET FNPT	CFM @ 100 PSI	PRICE CODE NO.
Tamper-proof design with special removable key. Maximum inlet pressure is 250 PSIG. Outlet pressure range is 5 to 125 PSIG.	1/4"	20	79-0305
	1/2"	50	79-0306
	3/4"	120	79-0307

Registered trademarks:
Viton, - DuPont Dow Elastomers; Santoprene - Advanced Elastomer Systems, L.P.;
Geolast - F.C. Witt Assoc., Inc.

PULSATION DAMPENERS



1" MANUAL MODEL

DESIGNED TO ELIMINATE PRESSURE SURGES AND PULSATIONS

- **Non metallic solution contact**
Polypropylene to 125 psig @ 175°F
PVDF to 125 psig @ 225°F
Nylon to 125 psig @ 175°F
- **Manual or automatic adjusting models.**
- **For pump sizes - 1/2", 1" or 2"**
- **Improve accuracy and life of pumps and meters.**
- **Stainless steel clamp band design for easy maintenance.**
- **One-way air inlet valve prevents product backflow if bladder is ruptured.**
- **Eliminates costly pipe system vibration and leakage.**

Pulsation dampeners are uniquely designed to eliminate 97% of all types of fluid flow pressure spikes. The unwanted result of these pressure spikes is hydraulic shock, material foaming or material splashing.

Pulsation dampeners reliably protect diaphragm pumps, pipes, fittings and equipment from vibration and fatigue. Pumps and filter chambers last longer and are more reliable when they are not exposed to harmful fluid shock waves. Installation is easy. Connect to fluid line via tee and supply compressed air or nitrogen to charge the dampener.

The highly efficient dampening provided by these devices makes them ideal for use as a suction stabilizer on all types of pumps or after valves to also protect downstream equipment.

Pulsation dampeners come in two models — Manual adjustment for continuous dampening requirements and Automatic adjusting for variable pump discharge pressures. Models are available in three sizes.

TYPICAL INSTALLATION

SUCTION SIDE -

Dampener acts as an accumulator to provide a close source of product when pump inlet check balls are opened. Helps prevent cavitation. Acts as a dampener when high inlet pressures are generated as pump's inlet check valves are closed. Minimizing stress and shock on pipes, fittings, manifolds and extends diaphragm life.

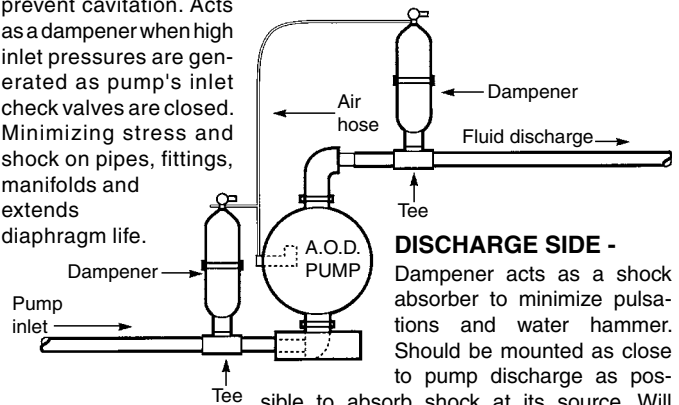

DISCHARGE SIDE -

Dampener acts as a shock absorber to minimize pulsations and water hammer. Should be mounted as close to pump discharge as possible to absorb shock at its source. Will prevent leaking joints and fittings due to pulsation. Allows meters to be used without damage and extends the life and reliability of pump components.

TO ORDER

NPT SIZE	MODEL	PRICE CODE NO.	MATERIAL	ADDTO		ADJUSTMENT	ADDTO		BLADDER MATERIAL	ADDTO	
				MODEL NO.	PRICE CODE NO.		MODEL NO.	PRICE CODE NO.		MODEL NO.	PRICE CODE NO.
1/2"	Dampener-1/2	55-73	Polypropylene	PP	0	Manual	M	0	Buna N	B	- B
1"	Dampener-1	55-74	(glass fiber)	N	1					L	- L
2"	Dampener-2	55-75	Nylon	N	1	Automatic	A	1	Viton®	V	- V
			PVDF	K	2					T	- T

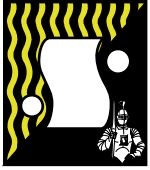

SERFILCO[®], LTD.

2900 MacArthur Blvd. 847-559-1777
Northbrook, IL 60062-2005 U.S.A. 800-323-5431
e-mail: sales@serfilco.com FAX: 847-559-1995
www.serfilco.com

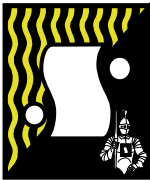

PUMPS by SERFILCO[®]

*MANUFACTURERS of PUMPS &
FILTER SYSTEMS for INDUSTRY
Worldwide*

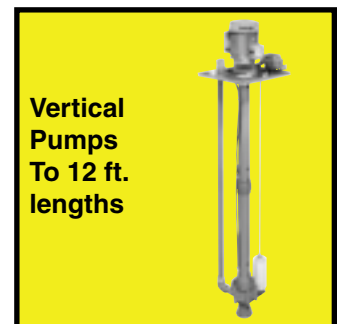
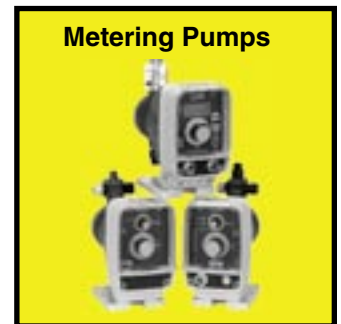

THERE'S A RIGHT SERFILCO PUMP FOR YOU!