

SERFILCO®

SPACE-SAVER® 'J' FILTRATION SYSTEMS

BULLETIN
F-215B
MAY 2002

COMPACT, HIGH FLOW FILTRATION, CARBON OR RESIN PURIFICATION

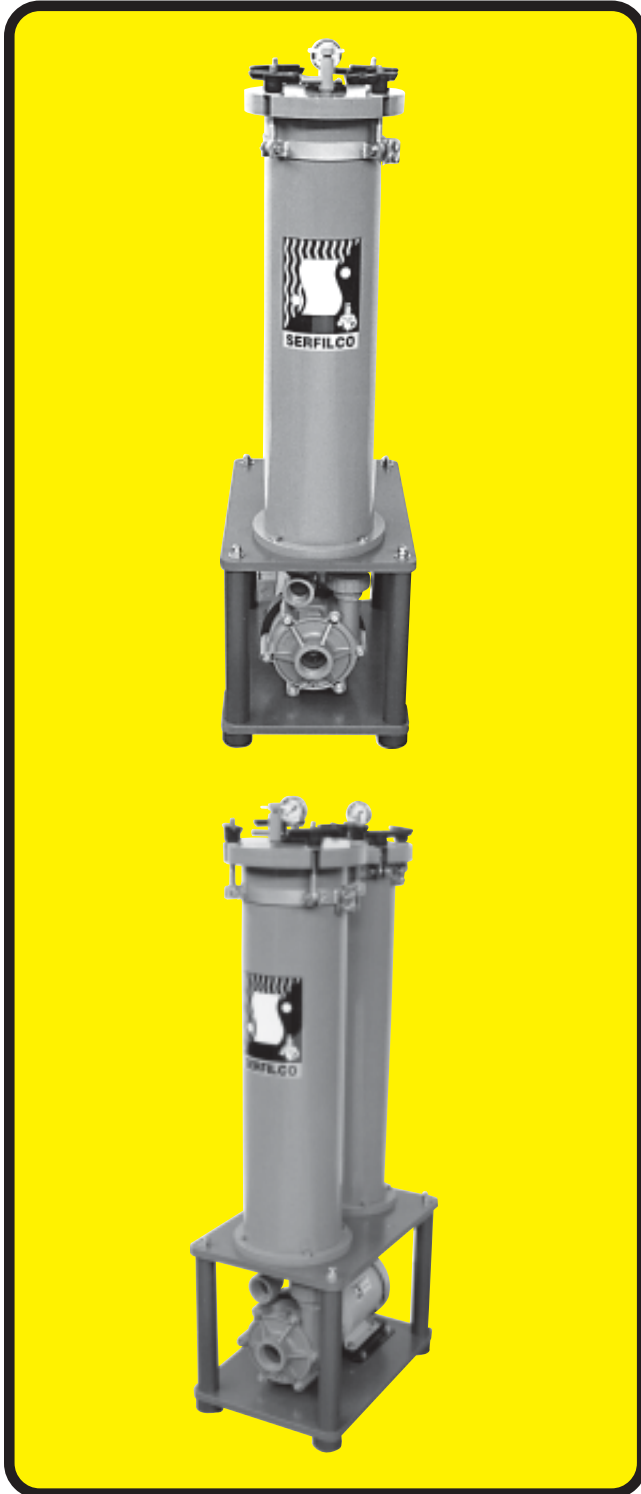

The SERFILCO Space-Saver 'J' Series is engineered to provide reliable, high performance filtration in a small package.

These compact pump and filter systems are popular for use on medium sized production tanks in the electronics and metal finishing industries.

Featuring SERFILCO's non-metallic, leak-proof magnetic coupled pumps and industry proven Series 'J' filter chambers, these systems provide high flow and high turnover rates, assuring continuous particle removal. Space-Saver 'J' systems are available with or without a carbon or resin purification chamber.

- **Choice of pump**

- Seal-less magnetic drive pumps:*

- Highly efficient seal-less magnetic coupled pumps provide total solution containment and reliable performance. The pumps are polypropylene with EPDM "O"-ring.

- Mechanical seal pumps:*

- Single or double mechanical seals constructed of CPVC with EPDM elastomers and the highest grade, longest lasting silicon carbide seal faces.

- **Filter chamber**

- Constructed of PVC or CPVC with EPDM elastomers to ensure chemical and temperature compatibility.

- The standard chamber accepts double open end (DOE) depth wound, pleated, melt blown, cleanable sleeve and carbon cartridges. A 222 "O"-ring seat for single open end (SOE) cartridges is available.

- **Simple carbon or resin treatment**

- Space-Saver 'J' systems are also available with optional purification chambers in PVC or CPVC with reusable PVC canister offering a low-cost, but effective method of continuously or periodically removing organic impurities from plating baths and other chemical solutions.

SERFILCO — worldwide leader in service, dependability and design for over 40 years!

SPACE-SAVER 'J' FILTRATION SYSTEMS Specifications and performance

DIMENSIONS

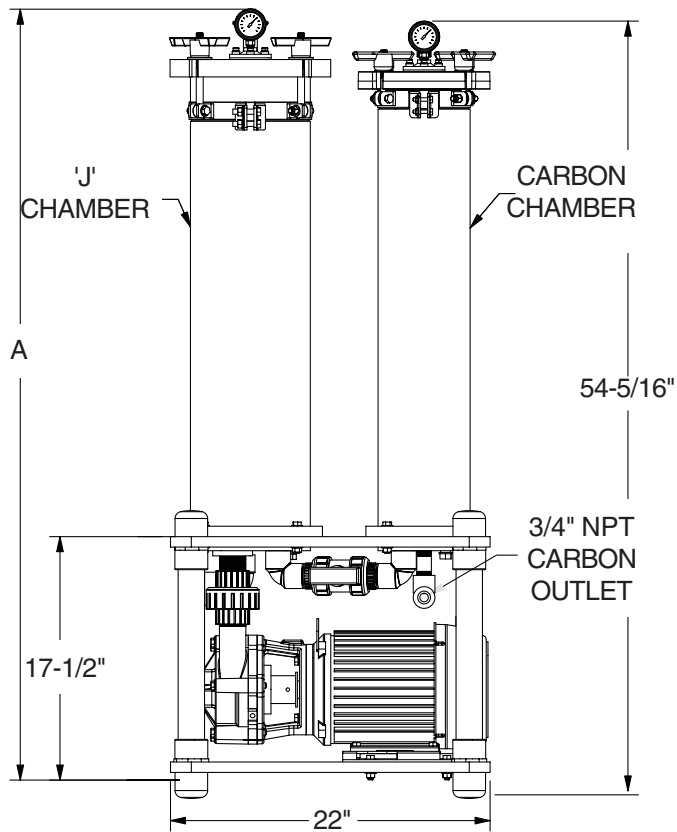

CHAMBER	A
J18	55-3/16"
J24	65-3/16"

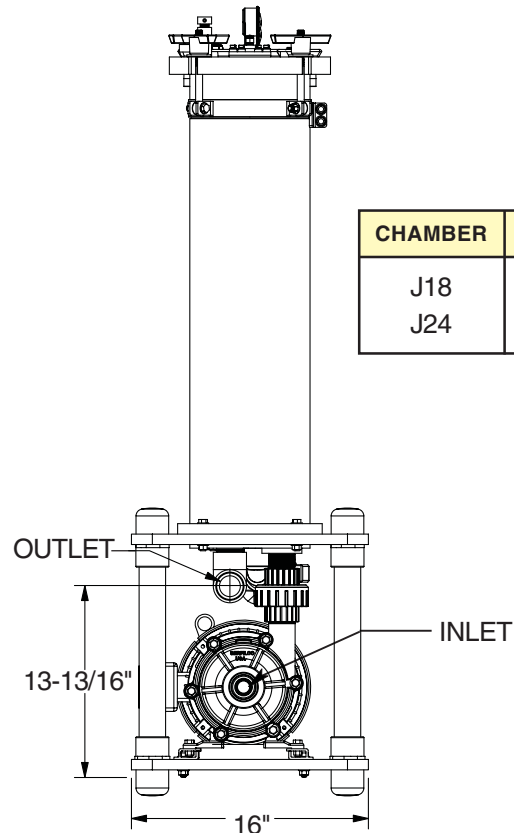

FLOW CURVES

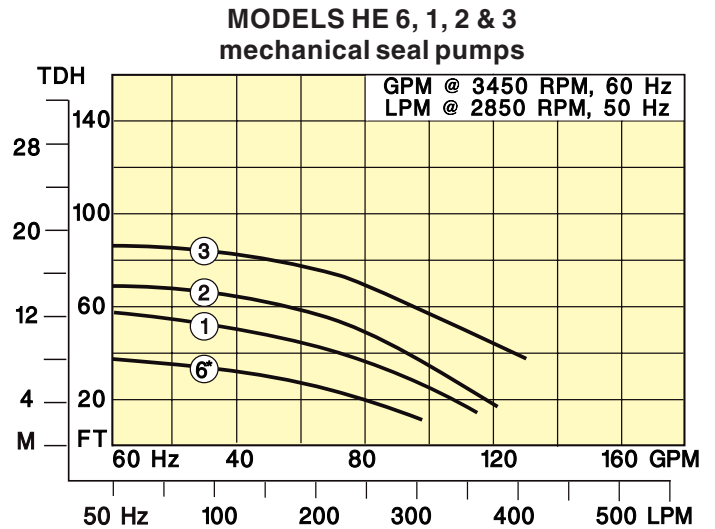
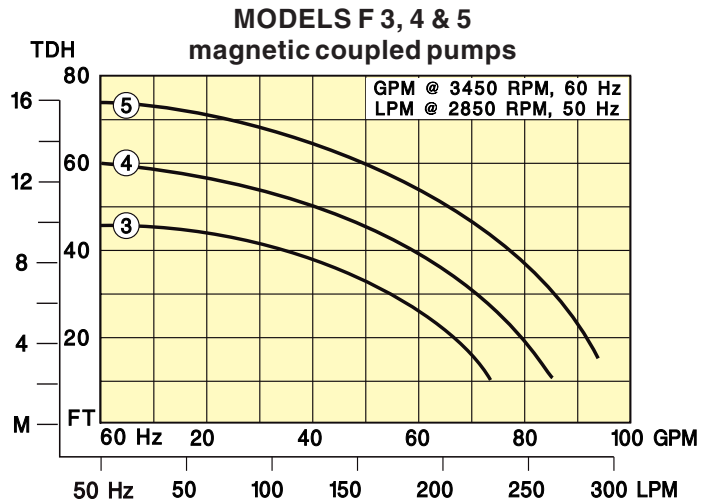
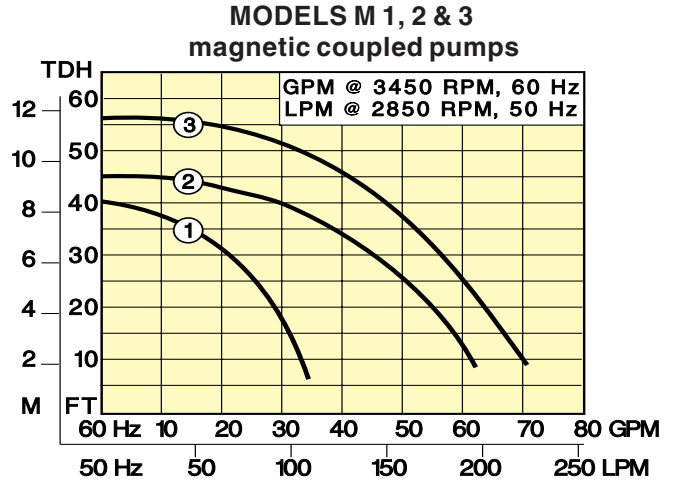

* 1.0 HP 'HE' pump is 1725 RPM @ 60 Hz, 1450 RPM @ 50 Hz

SPACE-SAVER 'J' FILTRATION SYSTEMS Specifications (continued)

All Space-Saver 'J' systems include the following standard features:

- Non-metallic solution contact
- Stainless steel external fasteners
- Swing bolt chamber closures
- EPDM elastomers standard
- Corrosion resistant PVC hooded base
- Corrosion resistant vent valve
- Industrial duty SERFILCO pump
- Hard piping and wet testing prior to shipping
- Glycerin filled stainless steel pressure gauge
- Silicon carbide seals on mechanical seal pumps
- Filter chamber bottom inlet for low pressure drop

Systems with polypropylene magnetic drive pump and CPVC or PVC¹ filter chamber

System Number	Flow Rate		Pump Series	Pump HP ³	Pump Max. PSI	Cartridge Change PSI	Filter Chamber Series	Media	Solids Area (sq. ft.)	Suction / Disch. Connections (inches)	Shipping Weight (lbs.)
	GPH @ 60 Hz	LPH @ 50 Hz									
CJ18M105	1,800	5,700	M	½	20	16	J	6 - 30"	63	1 x 1 FNPT	130
CJ24M105	1,800	5,700	M	½	20	16	J	6 - 40"	84	1 x 1 FNPT	140
CJ18M208	2,700	8,500	M	¾	24	20	J	6 - 30"	63	1½ x 1½ FNPT	135
CJ24M208	2,700	8,500	M	¾	24	20	J	6 - 40"	84	1½ x 1½ FNPT	145
CJ18M310	3,600	11,300	M	1.0	28	23	J	6 - 30"	63	1½ x 1½ FNPT	145
CJ24M310	3,600	11,300	M	1.0	28	23	J	6 - 40"	84	1½ x 1½ FNPT	155
CJ18F315	4,500	14,200	F	1.5	23	20	J	6 - 30"	63	1½ x 1½ FNPT	150
CJ24F315	4,500	14,200	F	1.5	23	20	J	6 - 40"	84	1½ x 1½ FNPT	160
CJ18F420	5,000	15,800	F	2.0	29	25	J	6 - 30"	63	1½ x 1½ FNPT	155
CJ24F420	5,000	15,800	F	2.0	29	25	J	6 - 40"	84	1½ x 1½ FNPT	165
CJ18F530	5,500	17,300	F	3.0	35	30	J	6 - 30"	63	1½ x 1½ FNPT	170
CJ24F530	5,500	17,300	F	3.0	35	30	J	6 - 40"	84	1½ x 1½ FNPT	180

Systems with CPVC single or double seal² direct drive pump and CPVC or PVC¹ filter chamber

System Number	Flow Rate		Pump Series	Pump HP ³	Pump Max. PSI	Cartridge Change PSI	Filter Chamber Series	Media	Solids Area (sq. ft.)	Suction / Disch. Connections (inches)	Shipping Weight (lbs.)
	GPH @ 60 Hz	LPH @ 50 Hz									
CJ18HE610	3,000	9,500	HE	1.0 ⁴	16	14	J	6 - 30"	63	2 x 1½ FNPT	155
CJ24HE610	3,000	9,500	HE	1.0 ⁴	16	14	J	6 - 40"	84	2 x 1½ FNPT	165
CJ18HE115	4,500	14,200	HE	1.5	24	19	J	6 - 30"	63	2 x 1½ FNPT	155
CJ24HE115	4,500	14,200	HE	1.5	24	19	J	6 - 40"	84	2 x 1½ FNPT	165
CJ18HE220	5,500	17,300	HE	2.0	29	26	J	6 - 30"	63	2 x 1½ FNPT	145
CJ24HE220	5,500	17,300	HE	2.0	29	26	J	6 - 40"	84	2 x 1½ FNPT	155
CJ18HE330	6,000	18,900	HE	3.0	36	32	J	6 - 30"	63	2 x 1½ FNPT	150
CJ24HE330	6,000	18,900	HE	3.0	36	32	J	6 - 40"	84	2 x 1½ FNPT	160

¹ Listed system includes CPVC chamber. To order system with PVC chamber, change the **C** to **P** in System No.

² To order pump with double mechanical seal, change **HE** to **HED** in System No.

³ Less than 1.0 HP — single phase standard. 1.0 HP and above — three phase standard.

⁴ 1.0 HP 'HE' pump is 1725 RPM @ 60 Hz, 1450 RPM @ 50 Hz

SPACE-SAVER 'J' FILTRATION SYSTEMS Optional equipment

OPTIONAL

CARBON PURIFICATION CHAMBER		
DESCRIPTION		ADD TO END OF SYSTEM NO.
Includes integral carbon chamber and flow control valve. Carbon outlet 3/4" NPT	PVC chamber, Single 5" x 28" canister, 7.5 lbs. capacity	P
	CPVC chamber, Single 5" x 28" canister, 7.5 lbs. capacity	C
	CPVC chamber, Single 5" x 28" Maxi-Carb cartridge, 3.0 lbs. carbon	M

Order carbon media from Bulletin M-305.

VITON® ELASTOMERS	ADD TO END OF SYSTEM NO.
Filter chamber and pump	V

MOTOR STARTERS		
NEMA 4X Watertight push button (mounted and wired)		PRICE CODE NO.
Add -S to motor starter Price Code No. when ordering motor starter for use with DRI-STOP® Pump Protector IMPORTANT: Specify operating voltage	115 - 230V/1/50-60	O-MS1P
	230 - 460V/3/50-60	O-MS3P

DRI-STOP® PUMP PROTECTOR	
DRI-STOP 2R for use with double mechanical seal pump.	O-2DS2R
DRI-STOP 3 for use with magnetic drive or single mechanical seal pump.	O-DS3C

OPERATING VOLTAGE	
1 horsepower and above - Single phase	O-1PH
Under 1 horsepower - Three phase	O-3PH

50 Hz OPERATION	
Single phase @ 50 Hz	O-150H
Three phase @ 50 Hz	O-350H

F.O.B. Northbrook, Illinois

Specifications subject to change without notice.

Registered trademark: Viton - DuPont Dow Elastomers

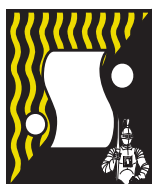

SERFILCO®, LTD.

2900 MacArthur Blvd. 847-509-2900
 Northbrook, IL 60062-2005 U.S.A. 800-323-5431
 e-mail: sales@serfilco.com FAX: 847-559-1995
 www.serfilco.com

DISTRIBUTED BY