

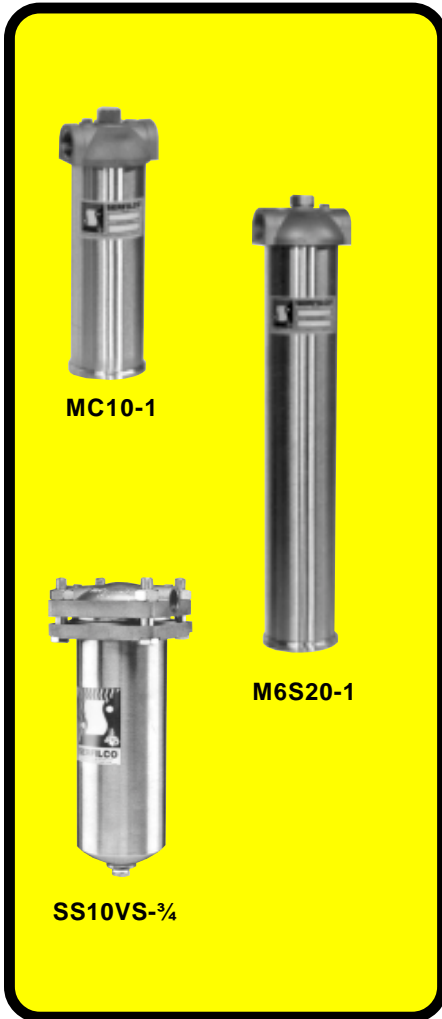

SERIES 'M' STEEL AND STAINLESS STEEL FILTER CHAMBERS

C-201N

FOR FILTRATION AND PURIFICATION OF:
WATER / PHOTOGRAPHIC / SOLVENTS / CHEMICALS
PHARMACEUTICAL / OILS / WASTE TREATMENT



SINGLE CARTRIDGE CHAMBERS

STEEL - Painted two-part epoxy gray on exterior.					
MODEL	MATERIAL	MAXIMUM PRESSURE	PORT SIZE	NO. FILTER CARTRIDGES	PRICE CODE NO.
MC10-1/2	Carbon steel and cast iron, 304 stainless steel centering spring Buna N shell gasket ¹	250 PSI	1/2" NPT	1	78-1500
MC10-3/4			3/4" NPT	1	78-1501
MC10-1			1" NPT	1	78-1502
MC20-3/4			3/4" NPT	2	78-1503
MC20-1			1" NPT	2	78-1504
MC30-3/4			3/4" NPT	3	78-1505
MC30-1	1" NPT	3	78-1506		

STAINLESS STEEL					
M4S10-3/4	304 stainless steel, 304 stainless steel centering spring Buna N shell gasket ¹	250 PSI	3/4" NPT	1	78-1507
M4S10-1			1" NPT	1	78-1508
M4S20-3/4			3/4" NPT	2	78-1509
M4S20-1			1" NPT	2	78-1510
M4S30-3/4			3/4" NPT	3	78-1511
M4S30-1			1" NPT	3	78-1512
M6S10-3/4	316 stainless steel, 304 stainless steel centering spring Buna N shell gasket ¹	250 PSI	3/4" NPT	1	78-1513
M6S10-1			1" NPT	1	78-1514
M6S20-3/4			3/4" NPT	2	78-1515
M6S20-1			1" NPT	2	78-1516
M6S30-3/4			3/4" NPT	3	78-1517
M6S30-1			1" NPT	3	78-1518
SS10-3/4HP	316 stainless steel	750 PSI	3/4" NPT	1	78-0876
SS20-3/4HP	EPDM "O" ring	750 PSI		2	78-0877
SS10VS-3/4	for fixed length	250 PSI		1	78-0878
SS20VS-3/4	cartridge	250 PSI		2	78-0880

¹ Fiber gasket at vent, drain and center nut.

Viton® elastomers: Add -V to Model and suffix V to Price Code No.

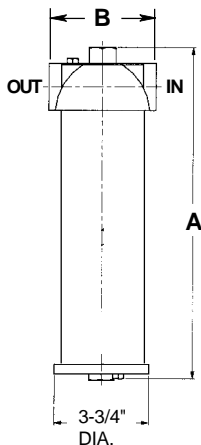

MODEL NO.	DIMENSIONS (In.)		SHIP WT. (lbs.)
	A	B	
M*10-1/2	12 7/8	4	6
M*10-3/4	12 7/8	4	6
M*10-1	13 1/8	4 1/4	7
M*20-3/4	23	4	8
M*20-1	23 1/4	4 1/4	9
M*30-3/4	33	4	11
M*30-1	33 1/4	4 1/4	12

* C for carbon steel, 4S for 304SS or 6S for 316SS

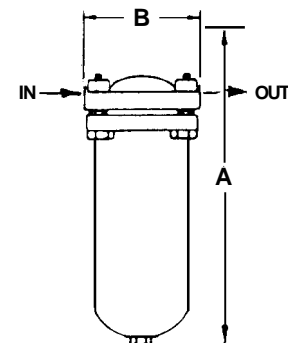

MODEL NO.	DIMENSIONS (In.)		SHIP WT. (lbs.)
	A	B	
SS10-3/4HP	13		10
SS20-3/4HP	23	4 3/8	13
SS10VS-3/4	13		10
SS20VS-3/4	23		13

SERIES 'M' FILTER CHAMBERS (cont'd)



MULTIPLE CARTRIDGE CHAMBERS

STEEL - Painted two-part epoxy gray on exterior.					
MODEL	MATERIAL	MAXIMUM PRESSURE	PORT SIZE	NO. FILTER CARTRIDGES	PRICE CODE NO.
S50(1)-2	Carbon steel with mounting legs Buna N gasket	100 PSI	2" MNPT	5	78-0882
S100(2)-2				10	78-0883
S150(3)-2				15	78-0884

STAINLESS STEEL					
MODEL	MATERIAL	MAXIMUM PRESSURE	PORT SIZE	NO. FILTER CARTRIDGES	PRICE CODE NO.
SS50(1)-2	304 stainless steel w/mounting legs Buna N gasket	100 PSI	2" MNPT	5	78-0885
SS100(2)-2				10	78-0886
SS150(3)-2				15	78-0887

Viton® elastomers: Add **V** to Model and suffix **V** to Price Code Number.

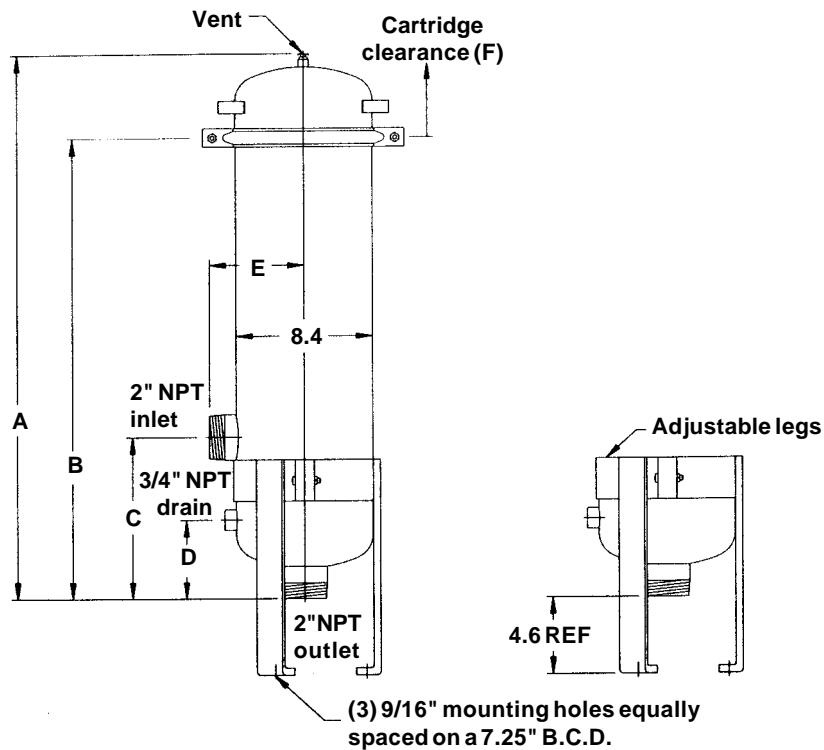

MODEL NO.	DIMENSIONS (In.)						SHIP WT. (lbs.)
	A	B	C	D	E	F	
(S)S50(1)-2	27	21-3/4	9-11/16	4-3/4	6	10	45
(S)S100(2)-2	37-1/16	31-13/16				20	55
(S)S150(3)-2	47-1/8	41-7/8				30	65

Specifications subject to change without notice.