

# SERFILCO®

## HEATERS and HEAT EXCHANGER COILS

BULLETIN  
A-102M  
SEPT. 2004

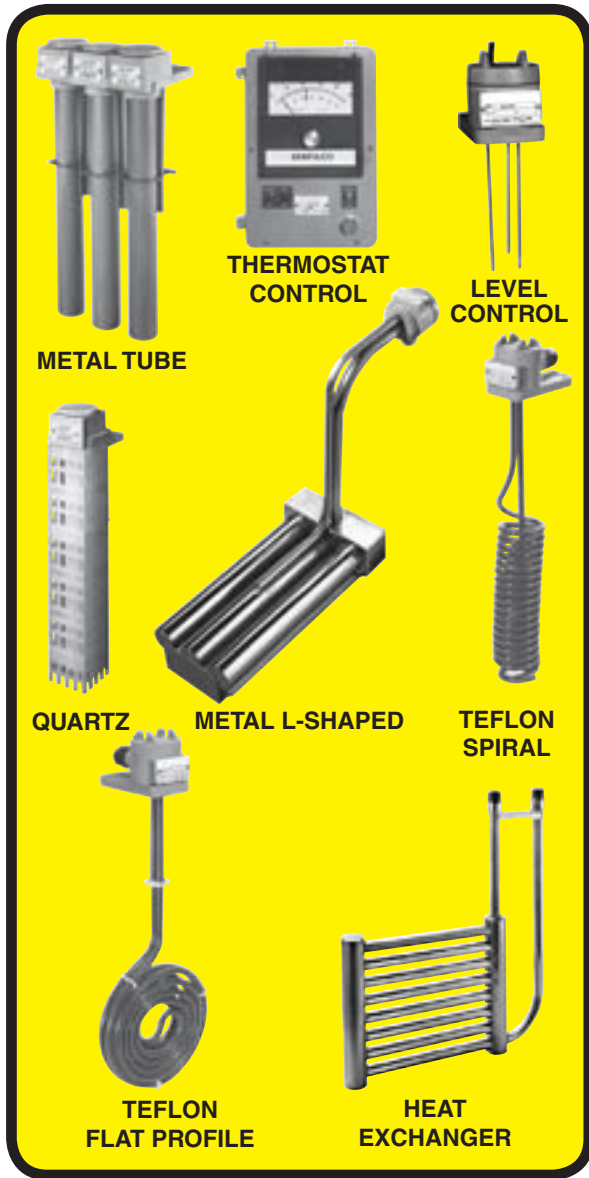

**HEATERS WITH "SAFEGUARD" CONTROLS PROVIDE SAFE, EFFICIENT AND ECONOMICAL HEATING FOR:**

***PLATING / PICKLING / RINSING  
ANODIZING / D.I. WATER / DYES  
ACIDS / ALKALIES / CLEANERS  
and OTHER AQUEOUS SOLUTIONS***



- **Heaters**  
Available in a variety of configurations in steel, 304 SS, 316 SS, titanium, quartz, and Teflon®
- **Thermostat controls and liquid level sensors for safe operation**
- **Heat exchanger coils**  
Metal coils in 316 SS and titanium; fluoropolymer tube coils

## THERMAL OVERLOAD PROTECTION

### Protector I, II and III-Series

#### **PROTECTOR I SERIES (Standard on all electric immersion heaters)**

The Protector I over-temperature control system utilizes a heat sensitive fuse to detect overheating conditions. The fuse, placed inside a thermowell, positioned in contact with the heater sheath, will cut power to the heater in the event of a low liquid level.

#### **PROTECTOR II AND PROTECTOR III SERIES (Optional - Consult Sales Dept.)**

The Protector II and Protector III systems provide the same

reliable over-temperature protection as the Protector I; however, the control systems feature a heat sensing thermostat. Should the tank's liquid level drop to a preset over-heat point, the thermostat will trip and an audible alarm will sound, as well as cutting power to the heater. This eliminates dangerous operating conditions. After filling the tank, the immersion heater can be quickly made operational by pushing the reset button on the control to restore power.

# DETERMINING SPECIFIC HEATING REQUIREMENTS FOR IMMERSION HEATERS

## TO DETERMINE THE HEATING REQUIREMENT OF A TANK

**Obtain the following information:**

1. TOTAL CUBIC FEET OF TANK. - Multiply the inside dimensions of the tank (depth x width x length). If the solution is normally 6" below the top of the tank, allow for this when calculating.
2. TOTAL GALLONS OF SOLUTION - Multiply by 7.48 the cubic feet of the tank occupied by solution.
3. AVERAGE AMBIENT (ROOM) TEMPERATURE WHERE TANK IS LOCATED.
4. TEMPERATURE LEVEL AT WHICH SOLUTION IS TO BE HELD.
5. HEAT-UP TIME DESIRED (HOURS).

**After this information is known, use the legend at right to make the calculations.**

$$\frac{A \times 1.0^* \times 8.35^{**} \times B}{3412 \times C} = \text{_____}$$

$$D \times E = \text{_____}$$

**Add the results of both calculations. The total is the Kilowatt requirement of the tank.**

**LEGEND**

- \* Specific heat of water. Insert specific heat of your solution here. If unavailable, use water value.
- \*\* Weight of water. Insert specific weight of your solution here. If unavailable, use water value.
- A** = Total gallons of solution
- B** = Difference between ambient temperature and desired-solution temperature.
- C** = Desired heat-up time (hours).
- D** = Heat loss of tank. Refer to "Surface Losses" chart below.
- E** = Square feet of top of tank (multiply length x width)

### SURFACE LOSSES IN KW from open hot water tank

80°	--	130°	.16	180°	.50
85°	.01	135°	.18	185°	.55
90°	.02	140°	.21	190°	.60
95°	.04	145°	.24	195°	.66
100°	.05	150°	.27	200°	.72
105°	.065	155°	.30	205°	.80
110°	.09	160°	.34	210°	.87
115°	.10	165°	.37	215°	.95
120°	.12	170°	.41	220°	1.04
125°	.14	175°	.45		

### TYPICAL HEATER INSTALLATION

Be certain heater is properly connected in compliance with all codes and per instructions which accompany heater.

Junction box must not be submerged.

Solution level must always remain above heated zone of heater.

Heater should remain at least 2" above sludge at bottom of tank.

**CAUTION:** All heated tanks should be equipped with an emergency automatic shut-off device.

Solution level must be at least one inch below junction box.

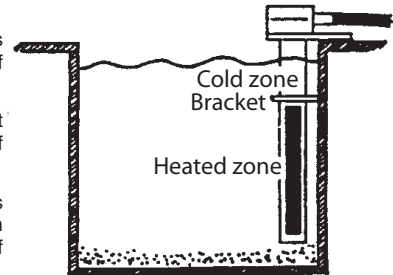

## AMPS FOR SELECTION OF CONTROLS

HEATER WATTS	AMPS FOR HEATING LOAD										
	SINGLE PHASE						THREE PHASE (BALANCED)				
	120V	208V	230V	240V	460V	480V	208V	230V	240V	460V	480V
1,000	8.4	4.8	4.4	4.2	2.2	2.1	2.8	2.6	2.5	1.3	1.2
2,000	16.7	9.7	8.7	8.4	4.4	4.2	5.6	5.1	4.9	2.6	2.5
3,000	25.0	14.5	13.1	12.5	6.6	6.3	8.4	7.6	7.3	3.8	3.7
4,000	33.4	19.3	17.4	16.7	8.7	8.4	11.2	10.1	9.7	5.9	4.9
6,000	50.0	28.9	26.1	25.0	13.1	12.5	16.7	15.1	14.5	7.6	7.3
8,000	66.7	38.5	34.8	33.4	17.4	16.7	22.3	20.2	19.3	10.1	9.7
9,000	75.0	43.3	39.2	37.5	19.6	18.8	25.1	22.7	21.7	11.4	10.9
12,000	100.0	57.7	52.2	50.0	26.1	25.0	33.4	30.2	29.0	15.1	14.5
18,000	150.0	86.6	78.3	75.0	39.2	37.5	50.1	45.3	43.4	22.7	21.7
27,000	225.0	129.9	117.4	112.5	58.7	56.3	75.1	67.9	65.1	34.0	32.6
36,000	300.0	173.1	156.6	150.0	78.3	75.0	100.1	90.5	86.8	45.3	43.4

# OVER-THE-SIDE HEATERS (OTS) - Spiral & Spiral-L

**TEFLON®**

## SINGLE ELEMENT SPIRAL OVER - THE - SIDE TEFLON IMMERSION HEATERS

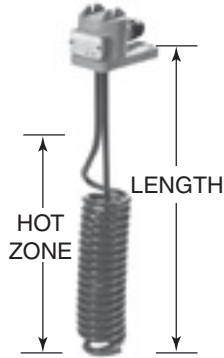

10 watts/square inch nominal.  
240 volts standard as listed -  
other voltages available.

Compatible with most plating tank solutions, inert to acids, anodizing and pickling solutions up to 212°F. temperature. Check Chemical Resistance Chart or with chemical supplier for proper material selection.  
Replaces alumina or graphite heaters.

### FEATURES:

- Low watt density for long service life.
- Non-contaminating Teflon covered stainless steel elements.
- PTI or PTLI thermal protection standard.
- Grounded internal metal element for safety.
- U.L. listed, CSA certified.
- Lightweight, non-floating construction.
- Standard 3' flexible PVC liquid-tight conduit.
- Polypropylene or Teflon guards optional. Consult Sales Dept.
- Single phase only
- Longer lengths available.
- Vapor-tight polypropylene terminal enclosure.

## SINGLE ELEMENT SPIRAL L-SHAPED TEFLON IMMERSION HEATERS

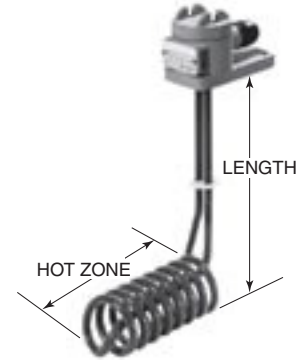

Bottom design for even heating and  
varying liquid levels.

WATTS	VOLTS*	HOT ZONE Inches	VERT.* LENGTH Inches	PRICE CODE NUMBER	SHIP WT. lbs.
500	240	5	11	79-1000XAA1	6
1,000	240	7	11	79-1001XAA1	7
2,000	240	11	17	79-1002XAA1	8
3,000	240	15	23	79-1003XAA1	13
4,000	240	19	29	79-1004XAA1	15
5,000	240	24	35	79-1005XAA1	18
6,000	240	29	40	79-1006XAA1	21
8,000	240	37	47	79-1007XAA1	25
9,000	240	44	54	79-1008XAA1	28

WATTS	VOLTS*	HOT ZONE Inches	VERT.* LENGTH Inches	PRICE CODE NUMBER	SHIP WT. lbs.
500	240	6	12	79-1009XAA1	6
1,000	240	8	12	79-1010XAA1	7
2,000	240	12	18	79-1011XAA1	8
3,000	240	17	18	79-1012XAA1	13
4,000	240	20	18	79-1013XAA1	15
5,000	240	24	18	79-1014XAA1	18
6,000	240	29	18	79-1015XAA1	21
8,000	240	37	18	79-1016XAA1	26
9,000	240	44	18	79-1017XAA1	29

\* Consult Sales Dept. for other choices.

### PRICE CODE IDENTIFICATION

Price Code Number: 79- \_\_\_\_\_ #1 #2 #3 #4 #5

#1 HEATER MATERIAL	#2 VOLTAGE	#3 PROTECTOR Consult Sales Dept.	#4 PHASE
X = PTFE (Teflon) Q = Quarts P = Plain steel F = 304 stainless steel S = 316 stainless steel T = Titanium	A = 240V B = 480V C = 120V D = 208V E = 415V G = 600V H = 380V	Replaceable PI A = to 180°F B = 180-230°F C = 230-300°F Resettable PII or PIII D = to 180°F E = 180-230°F F = 230-300°F	1 = 1φ 3 = 3φ
			#5 OPTIONS

# OVER-THE-SIDE HEATERS (OTS) - Coil - Flat & Flat-L

**TEFLON®**

## SINGLE ELEMENT FLAT OVER-THE-SIDE TEFLON

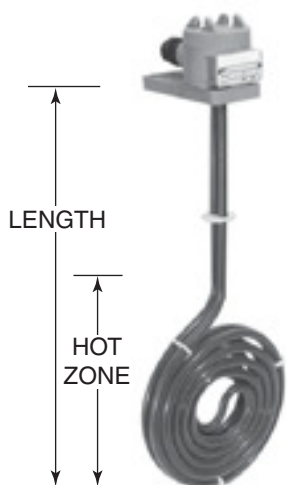

Flat, low profile design.

Compatible with most plating tank solutions, inert to acids, anodizing and pickling solutions up to 212°F. temperature. Check Chemical Resistance Chart or with chemical supplier for proper material selection. Replaces alumina or graphite heaters.

### FEATURES:

- Low watt density for long service life.
- Non-contaminating Teflon covered stainless steel element.
- PTI or PTLI thermal protection standard
- U.L. listed, CSA certified.
- Lightweight, non-floating construction.
- Vapor-tight polypropylene terminal enclosure.
- Standard 3' flexible PVC liquid-tight conduit.
- Polypropylene or Teflon guards optional. Consult Sales Dept.
- Single phase only
- Grounded internal metal element for safety.
- Longer vertical lengths available.

## SINGLE ELEMENT FLAT L-SHAPED TEFLON IMMERSION HEATERS

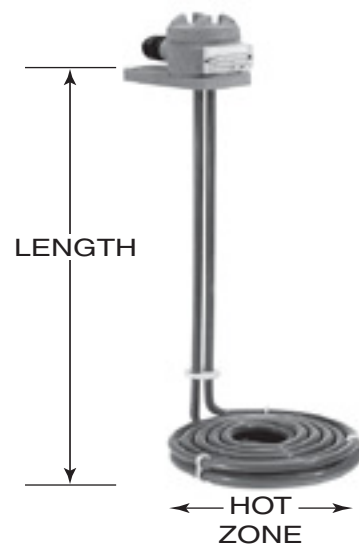

10 watts/square inch nominal  
240 volts standard as listed - other volt-  
ages available.  
Low profile bottom design for even  
heating and varying liquid levels.

WATTS	VOLTS*	HOT ZONE Inches	VERT.* LENGTH Inches	DIA.* inches	PRICE CODE NUMBER	SHIP WT. lbs.
500	240	6	14	5	79-1018XAA1	6
1,000	240	7	14	6	79-1019XAA1	7
2,000	240	9	17	8	79-1020XAA1	8
3,000	240	10	23	9	79-1021XAA1	13
4,000	240	12	29	11	79-1022XAA1	15
5,000	240	13	35	12	79-1023XAA1	18
6,000	240	14	40	13	79-1024XAA1	22
8,000	240	16	40	15	79-1025XAA1	25
9,000	240	17	40	16	79-1026XAA1	28

WATTS	VOLTS*	HOT ZONE Inches	VERT.* LENGTH Inches	DIA.* inches	PRICE CODE NUMBER	SHIP WT. lbs.
500	240	5	12	5	79-1027XAA1	6
1,000	240	6	12	6	79-1028XAA1	7
2,000	240	8	18	8	79-1029XAA1	8
3,000	240	9	18	9	79-1030XAA1	13
4,000	240	11	18	11	79-1031XAA1	15
5,000	240	12	18	12	79-1032XAA1	18
6,000	240	13	18	13	79-1033XAA1	22
8,000	240	15	18	15	79-1034XAA1	26
9,000	240	16	18	16	79-1035XAA1	29

\* Consult Sales Dept. for other choices.

# OVER-THE-SIDE HEATERS (OTS) - Loop

TEFLON®

## SIX ELEMENT OVER - THE - SIDE TEFLON IMMERSION HEATERS

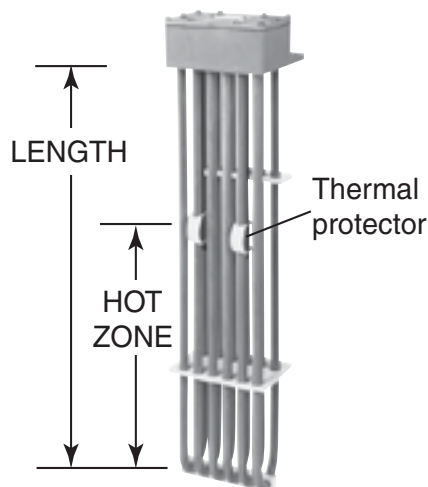

10 watts/square inch nominal  
240 volts standard as listed -  
other voltages available.

Compatible with most plating tank solutions, inert to acids, anodizing and pickling solutions up to 212°F. temperature. Check Chemical Resistance Chart or with chemical supplier for proper material selection. Replaces alumina or graphite heaters.

### FEATURES:

- U.L. listed, CSA certified.
- Low watt density for long service life.
- Non-contaminating Teflon covered stainless steel elements.
- PTI thermal protection standard.
- Grounded internal metal element for safety.
- Lightweight, non-floating construction.
- Vapor-tight polypropylene terminal enclosure.
- Standard 3' flexible PVC liquid-tight conduit.
- Polypropylene or Teflon guards optional. Consult Sales Dept.
- Standard 3-phase wiring. Consult Sales Dept. for optional single phase.

## NINE ELEMENT OVER - THE - SIDE TEFLON IMMERSION HEATERS

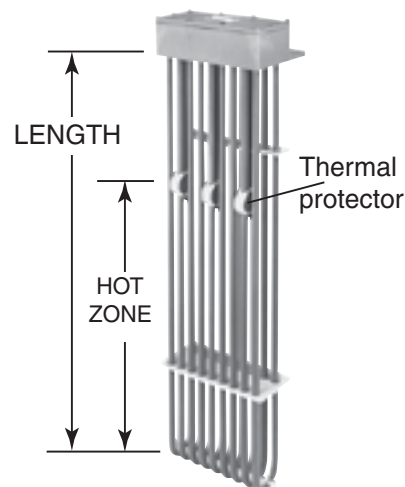

3 to 18 kw, 10 watts/square inch nominal  
240 volts standard as listed - other voltages available.

WATTS	VOLTS*	HOT ZONE inches	LENGTH inches	PRICE CODE NUMBER	SHIP WT. lbs
2,000	240	9	17	79-1069XAA3	19
3,000	240	15	23	79-1070XAA3	22
4,000	240	21	29	79-1071XAA3	24
6,000	240	28	35	79-1072XAA3	27
8,000	240	38	47	79-1073XAA3	33
10,000	240	47	59	79-1074XAA3	40
12,000	240	55	68	79-1075XAA3	45

WATTS	VOLTS*	HOT ZONE inches	LENGTH inches	PRICE CODE NUMBER	SHIP WT. lbs
3,000	240	9	17	79-1076XAA3	28
4,500	240	15	23	79-1077XAA3	33
6,000	240	21	29	79-1078XAA3	36
9,000	240	28	35	79-1079XAA3	40
12,000	240	38	47	79-1080XAA3	49
15,000	240	47	59	79-1081XAA3	60
18,000	240	55	68	79-1082XAA3	67

\* Consult Sales Dept. for other choices.

# OVER-THE-SIDE HEATERS (OTS) - Tubular

## SINGLE TUBE

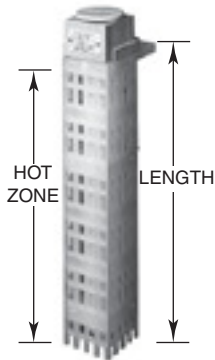

26 watts/square inch nominal.  
240 volts standard as listed, other voltages available.

For plating tanks, pickling and other acidic aqueous solutions. Check Chemical Resistance Chart or with chemical supplier for proper material selection.

**Not for use in hydrofluoric acid or alkaline solutions.**

### FEATURES:

- Heavy duty, long lasting construction.
- PQI thermal protection standard
- Grounded for safety.
- U.L. listed, CSA certified.
- Vapor-tight polypropylene terminal enclosure.
- Standard 3' flexible PVC liquid-tight conduit.
- Replaceable elements and quartz tube.
- Complete standard heater provided with polypropylene guard, optional Teflon guard available for solutions over 200°F. and chromic acid.

## TRIPLE TUBE

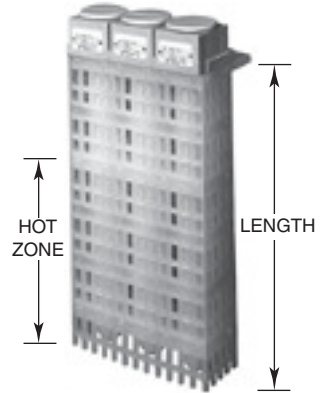

26 watts/square inch nominal.  
240 volts standard as listed, other voltages available.

WATTS	VOLTS	HOT ZONE inches	LENGTH* inches	PRICE CODE NUMBER	SHIP WT. lbs
500	240	6	10	79-1136QAA1C	9
1,000	240	7	11	79-1137QAA1C	10
1,000	240	7	17	79-1138QAA1C	11
2,000	240	12	17	79-1139QAA1C	11
2,000	240	12	23	79-1140QAA1C	14
3,000	240	18	23	79-1141QAA1C	14
3,000	240	18	29	79-1142QAA1C	17
3,500	240	21	29	79-1143QAA1C	17
4,000	240	28	35	79-1144QAA1C	20
4,000	240	28	41	79-1145QAA1C	23
5,000	240	33	41	79-1146QAA1C	23
5,000	240	33	47	79-1147QAA1C	26
6,000	240	39	47	79-1148QAA1C	26
6,000	240	39	52	79-1149QAA1C	29
8,000	240	49	59	79-1150QAA1C	31
10,000	240	62	71	79-1151QAA1C	34

WATTS	VOLTS	HOT ZONE inches	LENGTH* inches	PRICE CODE NUMBER	SHIP WT. lbs
1,500	240	6	10	79-1152QAA1C	21
3,000	240	7	11	79-1153QAA1C	22
3,000	240	7	17	79-1154QAA1C	26
6,000	240	12	17	79-1155QAA1C	26
6,000	240	12	23	79-1156QAA1C	30
9,000	240	18	23	79-1157QAA1C	30
9,000	240	18	29	79-1158QAA1C	34
10,500	240	21	29	79-1159QAA1C	34
12,000	240	28	35	79-1160QAA1C	38
12,000	240	28	41	79-1161QAA1C	44
15,000	240	33	41	79-1162QAA1C	44
15,000	240	33	47	79-1163QAA1C	48
18,000	240	39	47	79-1164QAA1C	48
18,000	240	39	52	79-1165QAA1C	52
24,000	240	49	59	79-1166QAA1C	55
30,000	240	62	71	79-1167QAA1C	65

Single phase standard. Consult Sales Dept. for optional 3 phase.

\* Consult Sales Dept. for other choices.

Standard design consists of three individual single phase heaters, which can be wired delta in the field to achieve a three phase balanced operating system. Individual elements are field replaceable.

# OVER-THE-SIDE HEATERS (OTS) - Tubular

# STEEL, STAINLESS STEEL and TITANIUM

## SINGLE TUBE METAL OVER - THE - SIDE IMMERSION HEATERS

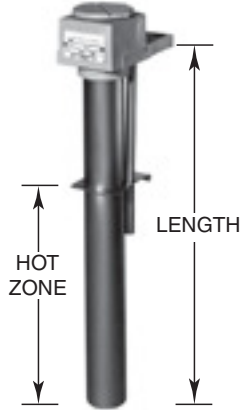

35 watts/square inch nominal  
240 volts standard as listed - other voltages available.  
Single phase standard. Consult Sales Dept. for optional 3 phase.  
Standard 3' flexible PVC liquid-tight conduit.

For plating tanks, rinse tanks and other aqueous solutions. Check Chemical Resistance Chart or with chemical supplier for proper material selection.

### FEATURES:

- Heavy duty, long lasting construction.
- PI thermal protection standard
- U.L. listed except plain steel, all CSA certified.
- Grounded for safety.
- Vapor tight polypropylene terminal enclosure.

## TRIPLE TUBE METAL OVER - THE - SIDE IMMERSION HEATERS

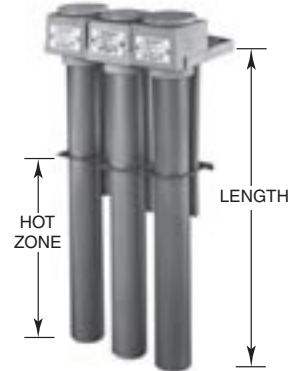

35 watts/square inch nominal  
240 volts standard as listed - other voltages available.  
Standard 3' flexible PVC liquid-tight conduit (one/element).  
Standard design consists of three individual single phase heaters which can be wired delta in the field to achieve a three-phase balanced operating system. Individual elements are field replaceable. Single common junction box available as option (three phase standard). Individual elements are not field replaceable with single box design.

WATTS	VOLTS	HOT ZONE inches	LENGTH inches	316 STAINLESS STEEL	SHIP WT. lbs.
1,000	240	6	11	79-1168SAA1	7
2,000	240	10	17	79-1169SAA1	10
3,000	240	16	23	79-1170SAA1	11
4,000	240	20	29	79-1171SAA1	13
5,000	240	25	35	79-1172SAA1	15
6,000	240	30	40	79-1173SAA1	17
8,000	240	37	47	79-1174SAA1	23
9,000	240	44	54	79-1175SAA1	24
10,000	240	49	59	79-1176SAA1	25
12,000	240	58	68	79-1177SAA1	28

WATTS	VOLTS	HOT ZONE inches	LENGTH inches	316 STAINLESS STEEL	SHIP WT. lbs.
3,000	240	6	11	79-1178SAA1	21
6,000	240	10	17	79-1179SAA1	30
9,000	240	16	23	79-1180SAA1	33
12,000	240	20	29	79-1181SAA1	39
15,000	240	25	35	79-1182SAA1	45
18,000	240	30	40	79-1183SAA1	51
24,000	240	37	47	79-1184SAA1	63
27,000	240	44	54	79-1185SAA1	69
30,000	240	49	59	79-1186SAA1	75
36,000	240	58	68	79-1187SAA1	84

<sup>1</sup> Consult Sales Dept. for other choices.

<sup>2</sup> For 304SS heater, change **S** to **F** in Price Code Number.  
For titanium heater, change **S** to **T** in Price Code Number.  
For plain steel, change **S** to **P** in Price Code Number.

# OVER-THE-SIDE HEATERS (OTS) - Tubular - L

# STEEL, STAINLESS STEEL and TITANIUM

## SINGLE TUBE METAL L-SHAPED IMMERSION HEATERS

(Riser height measured from bottom of sludge leg to bottom of gooseneck. Non-standard lengths are available.)

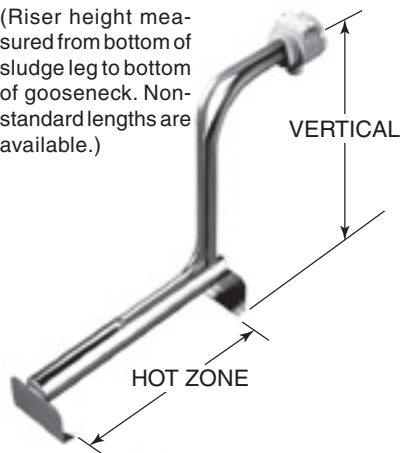

For plating tanks, rinse tanks and other non-sludging aqueous solutions. Check Chemical Resistance Chart or with chemical supplier for proper material selection.

### FEATURES:

- Bottom mount design for even heating and varying solution levels.
- Standard 2" sludge legs (longer available).
- Heavy duty, long lasting construction.
- PLI thermal protection standard
- U.L. listed except plain steel, all CSA certified.
- Grounded for safety.
- Vapor- tight polypropylene terminal enclosure.
- Standard 3' flexible PVC liquid-tight conduit.
- Optional Teflon flexible riser or straight vertical configuration available. (Consult Sales Dept).

35 watts/square inch nominal  
240 volts standard as listed - other voltages available.  
Single phase standard. Consult Sales Dept. for optional three phase.

## TRIPLE TUBE METAL L-SHAPED IMMERSION HEATERS

(Riser height measured from bottom of sludge leg to bottom of gooseneck. Non-standard lengths are available.)

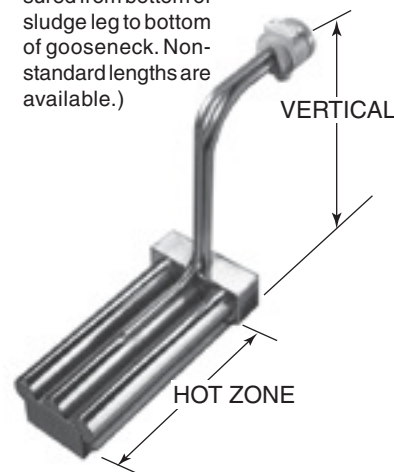

35 watts/square inch nominal  
240 volts standard as listed - other voltages available.  
Three phase standard. Consult Sales Dept. for optional single phase.

WATTS	VOLTS	HORIZ. inches	VERT. inches	316 STAINLESS STEEL	SHIP WT. lbs.
1,000	240	13	15	79-1208SAA1	10
2,000	240	17	19	79-1209SAA1	11
3,000	240	22	25	79-1210SAA1	12
4,000	240	26	25	79-1211SAA1	13
5,000	240	31	37	79-1212SAA1	14
6,000	240	36	50	79-1213SAA1	15
8,000	240	44	50	79-1214SAA1	18
9,000	240	50	50	79-1215SAA1	20
10,000	240	55	50	79-1216SAA1	22
12,000	240	64	50	79-1217SAA1	25

WATTS	VOLTS	HORIZ. 2 inches	VERT. 2 inches	316 STAINLESS STEEL <sup>1</sup>	SHIP WT. lbs.
3,000	240	13	15	79-1218SAA3	30
6,000	240	17	37	79-1219SAA3	33
9,000	240	22	37	79-1220SAA3	36
12,000	240	26	37	79-1221SAA3	39
15,000	240	31	37	79-1222SAA3	42
18,000	240	36	50	79-1223SAA3	45
24,000	240	44	50	79-1224SAA3	54
27,000	240	50	50	79-1225SAA3	60
30,000	240	55	50	79-1226SAA3	66
36,000	240	64	50	79-1227SAA3	75

<sup>1</sup> For 304SS heater, change **S** to **F** in Price Code Number.  
For titanium heater, change **S** to **T** in Price Code Number.  
For plain steel, change **S** to **P** in Price Code Number.

<sup>2</sup> Consult Sales Dept. for other choices.



**IGNITION  
SOURCE**

## WARNING

**ELECTRIC IMMERSION HEATERS WILL IGNITE  
MANY PLASTIC TANKS SUCH AS  
POLYPROPYLENE AND POLYETHYLENE AND  
SUBJECT PERSONNEL TO SHOCK HAZARD IF  
NOT PROPERLY INSTALLED AND MAINTAINED.**



**SHOCK  
HAZARD**



# THERMOSTATS AND LIQUID LEVEL SENSORS

## DIGITAL COMBINATION CONTROLS WITH STEPDOWN TRANSFORMER

Provides digital indication of setpoint and control point temperature.

- Single setpoint
- 1 or 3 phase controls with 5 ft. FEP sleeved sensor.
- -58°F to 302°F temperature range. (-50° to 150°C).
- cULus listed.
- ±1°F accuracy.
- Optional 10 ft. sensor
- Large LED readout.



ORDERING INFORMATION					
PRICE CODE NO.	MODEL NUMBER	VOLTS	MAX. AMPS	SHIP/WT. lbs/(Kg.)	OPTIONS*
79-1660 A	DLC 302	240	30	16	Add -LT to Price Code Number and Model Number for "less transformer".
79-1660 B	DLC 304	480		(7.5)	
79-1661 A	DLC 502	240	50	17	Transformer must be used at 480 volts.
79-1661 B	DLC 504	480		(8)	
79-1662 A	DLC 752	240	75	23	PII or PIII resettable systems (Consult Sales Dept.)
79-1662 B	DLC 754	480		(10.5)	
79-1663 A	DLC 902	240	90	25	*Consult Sales Dept. for other choices
79-1663 B	DLC 904	480		(11.5)	
79-1664 A	DLC 1202	240	120	27	
79-1664 B	DLC 1204	480		(12.5)	
79-1665 A	DLC 1502	240	150	33	
79-1665 B	DLC 1504	480		(15)	

## DIGITAL COMBINATION CONTROLS WITH STEPDOWN TRANSFORMER

Provides digital indication of setpoints and control point temperatures.

- Dual setpoints for heat / cool applications.
- 1 or 3 phase controls with 10 ft. FEP sleeved sensor.
- 0-500°F temperature range (Field selectable 0 - 260°C).
- cULus listed
- ±.25% accuracy (full span).
- Large LED readout.



ORDERING INFORMATION					
PRICE CODE NO.	MODEL NUMBER	VOLTS	MAX. AMPS	SHIP/WT. lbs/(Kg.)	OPTIONS*
79-1670 A	DQ 302	240	30	19	Add -LT to Price Code Number and Model Number for "less transformer".
79-1670 B	DQ 304	480		(8.5)	
79-1671 A	DQ 502	240	50	20	Transformer must be used at 480 volts.
79-1671 B	DQ 504	480		(9)	
79-1672 A	DQ 752	240	75	26	PII or PIII resettable systems (Consult Sales Dept.)
79-1672 B	DQ 754	480		(12)	
79-1673 A	DQ 902	240	90	28	*Consult Sales Dept. for other choices
79-1673 B	DQ 904	480		(13)	
79-1674 A	DQ 1202	240	120	30	
79-1674 B	DQ 1204	480		(13.5)	
79-1675 A	DQ 1502	240	150	36	
79-1675 B	DQ 1504	480		(16.5)	

## NON-INDICATING COMBINATION CONTROLS WITH STEPDOWN TRANSFORMER

For temperature control of heated aqueous solutions.

- Single setpoint
- 30°F to 220°F temperature range.
- 1 or 3 phase controls with 5 ft. FEP sleeved sensor.
- cULus listed.
- ±5°F accuracy.



FEP is fluorinated ethylene propylene fluoro polymer.

ORDERING INFORMATION					
PRICE CODE NO.	MODEL NUMBER	VOLTS	MAX. AMPS	SHIP/WT. lbs/(Kg.)	OPTIONS*
79-1534A	NR302	240	30	15	Add -LT to Price Code No. and Model No. for "less transformer".
79-1534B	NR304	480		(7)	
79-1535A	NR502	240	50	16	Transformer must be used at 480 volts.
79-1535B	NR504	480		(7.5)	
79-1536A	NR752	240	75	22	Add -H to Price Code No. and Model No. for high temp. model (150°F to 550°F)
79-1536B	NR754	480		(10)	
79-1537A	NR902	240	90	24	PII or PIII resettable systems (Consult Sales Dept.)
79-1537B	NR904	480		(11)	
79-1538A	NR1202	240	120	26	*Consult Sales Dept. for other choices
79-1538B	NR1204	480		(12)	
79-1539A	NR1502	240	150	32	
79-1539B	NR1504	480		(14.5)	

## LIQUID LEVEL SENSOR - SINGLE AND DUAL FUNCTION

For fluid processing and leak detection

**SERIES LC2** Single function probe  
Designed to control power to immersion heater should process solution drop below upper probe.

**SERIES LC3** Dual function probe  
Style same as above and also controls power to pump, solenoid valve or other equipment. 10 amp maximum.

- Prevents heater burn out from low liquid level.
- Designed for use in conductive solutions up to 70K OHMS resistance.
- PTFE covered stainless steel, titanium, Hastelloy® C or graphite probes available.

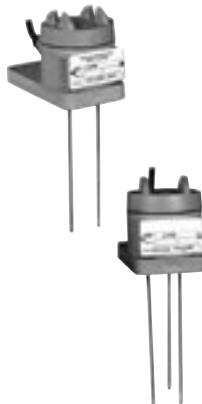

ORDERING INFORMATION					
LC SERIES — 2 PROBES			LC SERIES — 3 PROBES		
PRICE CODE NO.	MODEL NUMBER	PROBE LENGTH (FIELD TRIM) in.	PRICE CODE NO.	MODEL NUMBER	PROBE LENGTH (FIELD TRIM) in.
79-1510	LC2(* )6	6	79-1517	LC3(* )6	6
79-1511	LC2(* )12	12	79-1518	LC3(* )12	12
79-1512	LC2(* )18	18	79-1519	LC3(* )18	18
79-1513	LC2(* )24	24	79-1520	LC3(* )24	24
79-1514	LC2(* )30	30	79-1521	LC3(* )30	30
79-1515	LC2(* )36	36	79-1522	LC3(* )36	36
79-1516	LC2(* )48	48	79-1523	LC3(* )48	48

\* Designate material selection in Price Code Number and Model Number.  
S = 316 Stainless steel      T = Titanium  
H = Hastelloy                      G = Graphite (Not field trimmable)

# HEAT TRANSFER TUBE & COIL SIZING

## TEFLON and METAL

### QUICK ESTIMATION (BASED ON STEAM) HEAT-UP

- STEP 1** Determine gallons in tank.  
(U.S. Gal. = Tank Width \_\_\_" x Length \_\_\_" x Depth \_\_\_" ÷ 231.)  
Enter this amount at (A) in Formula 1.
- STEP 2** Subtract temperature of media to be heated from the temperature to which it must be heated.  
(Δ Temperature = Desired Temp. \_\_\_°F - Initial Temp. \_\_\_°F)  
Enter this amount at (B).
- STEP 3** Locate your useable steam pressure in Steam Pressure Factor chart and find the factor number. Enter this at (C).
- STEP 4** Multiply (A) times (B) times (C). Divide the product by 1000. This is the square foot area you require for a one hour heat-up. If more time is available, coil surface area may be reduced by dividing the square foot area by the heat-up time available, up to 4 hours maximum.

#### Formula 1

$$(A) \frac{\text{GALLONS}}{\text{GALLONS}} \times (B) \frac{\Delta T}{\Delta T} \times (C) \frac{\text{STEAM FACT.}}{\text{STEAM FACT.}} \div 1,000 = \text{FT}^2$$

### FORMULA FOR HOT WATER HEATING MEDIA

- STEP 1** Determine gallons in tank. Enter at (A) in Formula 2.
- STEP 2** Subtract temperature of media to be heated from the temperature to which it must be heated. Enter at (B).
- STEP 3** Multiply (A) times (B) times 8.33. Enter answer at (C).
- STEP 4** Subtract the required tank temperature from the temperature of your hot water supply. Enter this figure at (D).
- STEP 5** Multiply (D) by 100 for all metals or 30 for Teflon and enter answer at (E).
- STEP 6** Divide (C) by (E) to determine square feet of area required. If more time is available, coil surface area may be reduced by dividing the square foot area by the heat-up time available, up to 4 hours maximum.

#### Formula 2

$$(A) \frac{\text{gallons}}{\text{gallons}} \times (B) \frac{\Delta T}{\Delta T} \times 8.33 = \frac{(C)}{(E)} = \text{FT}^2 \text{ OF AREA REQ'D FOR ONE HOUR HEAT-UP}$$

100 (all metals) or 30 (Teflon) x (D) (Temp. rise required)

### STEAM PRESSURE FACTORS

Steam Pressure Available PSI	5	10	15	20	25	50
Steam Factor for Metal	.55	.50	.42	.37	.30	.25
Steam Factor for Teflon	2.75	2.50	2.10	1.85	1.50	___

Consult Sales Dept. for pressures above 50 lb. for metal and 30 lb. for Teflon.

### FORMULA FOR COOLING WITH ANY MEDIUM

This formula assumes that all electrical energy is dissipated in the tank as heat. In more efficient electrochemical conversions, the energy dissipated as heat may be less.

- STEP 1** Determine watts by multiplying voltage times amperage delivered by the tank rectifier. Multiply this product times 3.412 to determine BTU's. Enter answer at (A) in Formula 3.
- STEP 2** Subtract cooling liquid temperature from required tank temperature. Enter at (B). CAUTION: If this number is less than 15, consult Sales Dept. for assistance in determining proper coil size.
- STEP 3** Multiply (B) times 100 for all metals or 30 for Teflon and enter answer at (C).
- STEP 4** Divide (A) by (C) to determine square feet of surface area required.

#### Formula 3

$$(A) \frac{\text{volts} \times \text{amps} \times 3.412}{(B) \frac{\text{Req'd. tank temp. minus cooling liquid temp.} \times 100 \text{ (all metals) or } 30 \text{ (Teflon)}} = \frac{(A)}{(C)} = \text{FT}^2 \text{ OF SURFACE AREA REQUIRED}$$

**For a more in-depth analysis of your specific heat requirements, provide the following information and we will gladly size your heat exchanger.**

Initial temperature \_\_\_\_\_

Desired temperature \_\_\_\_\_

Tank size: Length \_\_\_\_\_ Width \_\_\_\_\_ Height \_\_\_\_\_

Solution depth \_\_\_\_\_

Type of solution to be heated or cooled \_\_\_\_\_

Production load: Lbs./hr. \_\_\_\_\_ & load temp. \_\_\_\_\_

Agitation (type) \_\_\_\_\_

Rectifiers: Number \_\_\_\_\_ Voltage \_\_\_\_\_ Amp \_\_\_\_\_

Covered or uncovered tank \_\_\_\_\_

Insulated tank & tank material \_\_\_\_\_

Steam pressure at coil hook-up point \_\_\_\_\_

Cooling media \_\_\_\_\_ Inlet temp. \_\_\_\_\_ Flow rate \_\_\_\_\_

**Maximum flow rates, performance curves and pressure drops are determined at the factory for optimum design efficiency. Contact us for performance data.**

# HEAT EXCHANGERS

## GRID and SERPENTINE COILS 316 STAINLESS, TITANIUM

### GRID COILS

#### VERTICAL GRID

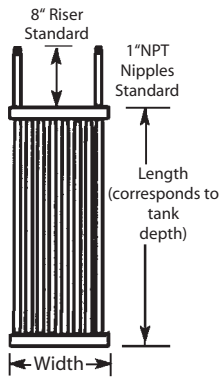

#### HORIZONTAL GRID

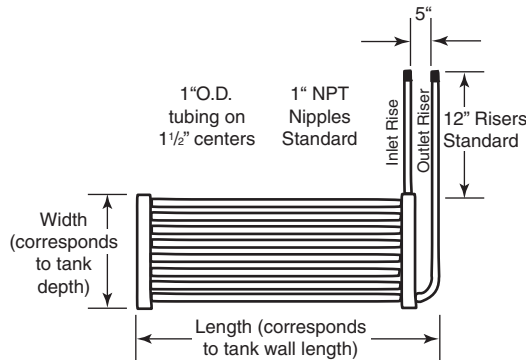

Where tank space is at a premium, the gridcoil is only 2" thick. The gridcoil permits full flow-through of solution for efficient heat transfer. Every square inch of surface is an active heat transfer area. Gridcoils can be banked or stacked for greater heat transfer.

Standard connections are 1" NPT nipples on 4" centers for serpentine and 5" centers for grids. 1" NPT nipples on variable centers for vertical models.

Gridcoils are offered in two styles - horizontal and vertical. However, the horizontal gridcoil is more commonly specified. Also, gridcoils can be operated in shallow

### SERPENTINE COILS (4-pass)

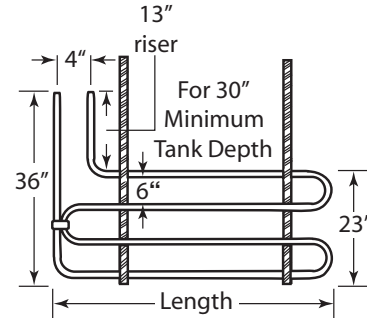

SURFACE AREA Sq. ft.	LENGTH in.	PRICE CODE NO. **	
		316 SS	TITANIUM
2.75	24	79-1432SA	79-1432TA
3.75	36	79-1432SB	79-1432TB
4.75	48	79-1432SC	79-1432TC
5.75	60	79-1432SD	79-1432TD
7.25	78	79-1432SE	79-1432TE
8.75	96	79-1432SF	79-1432TF

solutions - as low as 12". The vertical style is ideal for deep, narrow tanks or wells.

Serpentine coils offer lower cost per heating surface area. The design allows them to be installed in tanks with limited space.

### GRIDCOIL SPECIFICATIONS

SURFACE AREA Sq. ft.	COIL DIMENSIONS (inches)		NUMBER OF TUBES	PRICE CODE NUMBER <sup>1,2,3</sup> 316 SS
	WIDTH	LENGTH		
5.6	12-1/2	30	8	79-1442SB
6.7	12-1/2	36	8	79-1442SC
6.8	18-1/2	24	12	79-1443SA
8.4	18-1/2	30	12	79-1443SB
8.8	12-1/2	48	8	79-1442SD
9.4	24-1/2	24	16	79-1444SA
10.0	18-1/2	36	12	79-1443SC
11.5	24-1/2	30	16	79-1444SB
13.2	18-1/2	48	12	79-1443SD
13.6	24-1/2	36	16	79-1444SC
13.7	12-1/2	72	8	79-1442SF
13.7	36-1/2	24	24	79-1446SA
15.1	12-1/2	84	8	79-1442SG
15.8	42-1/2	24	28	79-1447SA
16.3	18-1/2	60	12	79-1443SE
16.8	36-1/2	30	24	79-1446SB
17.2	12-1/2	96	8	79-1442SH
17.8	24-1/2	48	16	79-1444SD
19.2	12-1/2	108	8	79-1442SJ
19.5	18-1/2	72	12	79-1443SF
19.5	42-1/2	30	28	79-1447SB
20.0	36-1/2	36	24	79-1446SC
22.0	24-1/2	60	16	79-1444SE
22.6	18-1/2	84	12	79-1443SG
23.2	42-1/2	36	28	79-1447SC
23.4	12-1/2	132	8	79-1442SL
25.7	18-1/2	96	12	79-1443SH
26.1	24-1/2	72	16	79-1444SF
26.3	36-1/2	48	24	79-1446SD
28.9	18-1/2	108	12	79-1443SJ
30.3	24-1/2	84	16	79-1444SG
30.6	42-1/2	48	28	79-1447SD

SURFACE AREA Sq. ft.	COIL DIMENSIONS (inches)		NUMBER OF TUBES	PRICE CODE NUMBER <sup>1,2,3</sup> 316 SS
	WIDTH	LENGTH		
32.0	18-1/2	120	12	79-1443SK
32.5	36-1/2	60	24	79-1446SE
34.5	24-1/2	96	16	79-1444SH
35.2	18-1/2	132	12	79-1443SL
38.0	42-1/2	60	28	79-1447SE
38.3	18-1/2	144	12	79-1443SM
38.7	24-1/2	108	16	79-1444SJ
38.8	36-1/2	72	24	79-1446SF
42.9	24-1/2	120	16	79-1444SK
45.1	36-1/2	84	24	79-1446SG
45.4	42-1/2	72	28	79-1447SF
47.1	24-1/2	132	16	79-1444SL
51.3	24-1/2	144	16	79-1444SM
51.4	36-1/2	96	24	79-1446SH
52.8	42-1/2	84	28	79-1447SG
57.7	36-1/2	108	24	79-1446SJ
60.2	42-1/2	96	28	79-1447SH
64.0	36-1/2	20	24	79-1446SK
67.6	42-1/2	108	28	79-1447SJ
70.3	36-1/2	132	24	79-1446SL
75.0	42-1/2	120	28	79-1447SK
76.6	36-1/2	144	24	79-1446SM
82.4	42-1/2	132	28	79-1447SL
89.8	42-1/2	144	28	79-1447SM

<sup>1</sup> For titanium grid coil change 'S' to 'T' in price code no.

<sup>2</sup> Add 'V' to end of price code no. for vertical style.  
Add 'H' to end of price code for horizontal style.

<sup>3</sup> Add 'S' to end of price code number for steam.  
Add 'W' to end of price code number for water

## HEAT EXCHANGERS

## FLUOROPOLYMER TUBE COILS

### STATE-OF-THE-ART IN HEAT

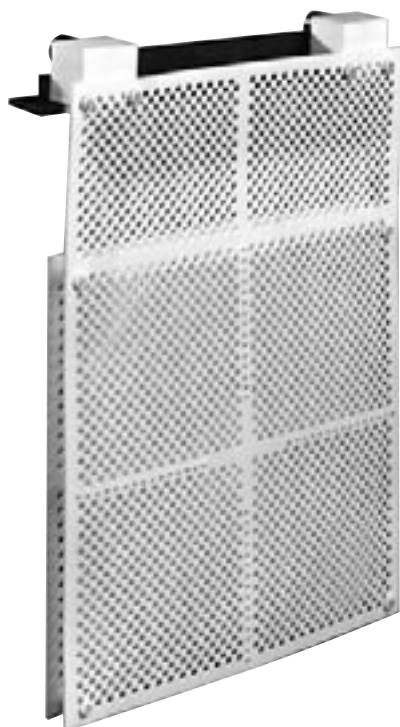

Unmatched for operating performance, installation ease and quality construction, tube coils are produced from high grade FEP with PTFE guard construction.

Compact tube coil exchangers maximize heating/cooling efficiency through a design that not only creates extremely high surface area, but also ensures outstanding flow-through circulation of the process bath by creating uniform spacing between the tubing. No other heat exchanger is faster or cheaper to install/service thanks to a unique design that incorporates a manifold into the heat exchanger package.

Only the highest quality components and craftsmanship go into the manufacture of these tube coils . . . so that you can expect outstanding performance and dependability over a long service life.

- **CONSTRUCTION FROM HIGH GRADE MATERIALS**  
**Frame** - high strength mechanical grade Teflon  
**Guard and fittings** - mechanical grade Teflon  
**Coil** - FEP (virgin fluorinated ethylene propylene) to 30 PSI steam or water (For up to 60 PSI steam or water, consult Sales Dept.)
- **NON-CONTAMINATING**
- **OUTSTANDING RESISTANCE TO VIRTUALLY ALL ACIDS AND ALKALIES**
- **SIZES FROM 2.25 FT.<sup>2</sup> OF EXCHANGE AREA TO 46.5 FT.<sup>2</sup>**
- **OTHER SIZES AVAILABLE**

#### CUSTOM COIL CAPABILITIES

We offer many standard model heat exchangers in a wide range of materials such as stainless steel, titanium and FEP. Custom configurations, high density exchange areas, special fittings on connections, and consideration for heating and/or cooling media (as in using a coil for an evaporator for a refrigeration system) are just a few. Consult Sales Dept.

#### MAINTENANCE

Due to the well known anti-stick properties of FEP, very little maintenance is required. However, when excessive build-up does occur, either chemically clean or pressure spray to clean.

#### DO NOT ATTEMPT TO CLEAN BY SCRAPING.

Manifold fittings may require slight re-tightening after the first 24 hours of use due to the cold flow properties of FEP. However, once re-tightened, no further tightening should be required.

#### TO ORDER - Select Price Code Number

1/4 TUBE COIL - Rectangular			
SURFACE AREA sq. ft.	CONNECTIONS in.	SIZE in	PRICE CODE NUMBER
2.25	1/2" FNPT	11 1/2 x 11 1/2 x 1 1/2	79-1478X
4.5	1/2" FNPT	11 1/2 x 11 1/2 x 2	79-1479X
4.5	1/2" FNPT	15 1/2 x 15 1/2 x 1 1/2	79-1480X
9.25	1/2" FNPT	15 1/2 x 15 1/2 x 2	79-1481X

1/2 TUBE COIL - Round			
SURFACE AREA sq. ft.	CONNECTIONS in.	PRICE CODE SIZE in.	PRICE CODE NUMBER
6	1" FNPT	17 1/2 x 17 1/2 x 2	79-1482X
12	1" FNPT	17 1/2 x 17 1/2 x 3 1/4	79-1483X
18	1 1/2" FNPT	17 1/2 x 17 1/2 x 4 1/2	79-1484X
24	1 1/2" FNPT	17 1/2 x 17 1/2 x 5 3/4	79-1485X
11.5	1" FNPT	23 1/2 x 23 1/2 x 2	79-1486X
23	1" FNPT	23 1/2 x 23 1/2 x 3 1/4	79-1487X
34.5	1 1/2" FNPT	23 1/2 x 23 1/2 x 4 1/2	79-1488X
46.5	1 1/2" FNPT	23 1/2 x 23 1/2 x 5 3/4	79-1489X

F.O.B. Northbrook, Illinois Specifications subject to change without notice.

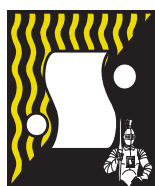

# SERFILCO<sup>®</sup>, LTD.

2900 MacArthur Blvd. 847-509-2900  
 Northbrook, IL 60062-2005 U.S.A. 800-323-5431  
 e-mail: sales@serfilco.com FAX: 847-559-1995  
 www.serfilco.com